

SERVICE MANUAL

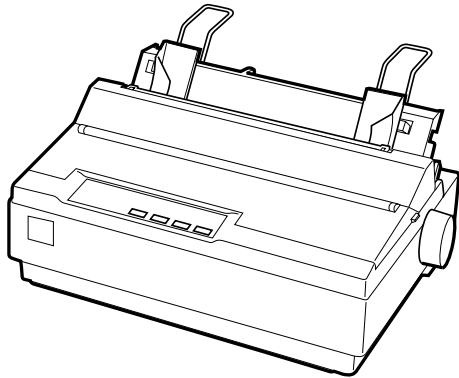

9-pin Serial Impact Dot Matrix Printer
EPSON LX-300+



EPSON®

Notice:

- All rights reserved. No part of this manual may be reproduced, stored in a retrieval system, or transmitted in any form or by any means, electronic, mechanical, photocopying, recording, or otherwise, without the prior written permission of SEIKO EPSON CORPORATION.
- The contents of this manual are subject to change without notice.
- All effort have been made to ensure the accuracy of the contents of this manual. However, should any errors be detected, SEIKO EPSON would greatly appreciate being informed of them.
- The above notwithstanding SEIKO EPSON CORPORATION can assume no responsibility for any errors in this manual or the consequences thereof.

EPSON is a registered trademark of SEIKO EPSON CORPORATION.

General Notice: Other product names used herein are for identification purpose only and may be trademarks or registered trademarks of their respective owners. EPSON disclaims any and all rights in those marks.

Copyright © 2000 SEIKO EPSON CORPORATION. Printed in Japan.

PRECAUTIONS

Precautionary notations throughout the text are categorized relative to 1) Personal injury and 2) damage to equipment.



Signals a precaution which, if ignored, could result in serious or fatal personal injury. Great caution should be exercised in performing procedures preceded by a **WARNING heading.**



Signals a precaution which, if ignored, could result in damage to equipment.

The precautionary measures itemized below should always be observed when performing repair/maintenance procedures.

DANGER

1. ALWAYS DISCONNECT THE PRODUCT FROM THE POWER SOURCE AND PERIPHERAL DEVICES PERFORMING ANY MAINTENANCE OR REPAIR PROCEDURES.
2. NOWORK SHOULD BE PERFORMED ON THE UNIT BY PERSONS UNFAMILIAR WITH BASIC SAFETY MEASURES AS DICTATED FOR ALL ELECTRONICS TECHNICIANS IN THEIR LINE OF WORK.
3. WHEN PERFORMING TESTING AS DICTATED WITHIN THIS MANUAL, DO NOT CONNECT THE UNIT TO A POWER SOURCE UNTIL INSTRUCTED TO DO SO. WHEN THE POWER SUPPLY CABLE MUST BE CONNECTED, USE EXTREME CAUTION IN WORKING ON POWER SUPPLY AND OTHER ELECTRONIC COMPONENTS.

WARNING

1. REPAIRS ON EPSON PRODUCT SHOULD BE PERFORMED ONLY BY AN EPSON CERTIFIED REPAIR TECHNICIAN.
2. MAKE CERTAIN THAT THE SOURCE VOLTAGES IS THE SAME AS THE RATED VOLTAGE, LISTED ON THE SERIAL NUMBER/RATING PLATE. IF THE EPSON PRODUCT HAS A PRIMARY AC RATING DIFFERENT FROM AVAILABLE POWER SOURCE, DO NOT CONNECT IT TO THE POWER SOURCE.
3. ALWAYS VERIFY THAT THE EPSON PRODUCT HAS BEEN DISCONNECTED FROM THE POWER SOURCE BEFORE REMOVING OR REPLACING PRINTED CIRCUIT BOARDS AND/OR INDIVIDUAL CHIPS.
4. IN ORDER TO PROTECT SENSITIVE MICROPROCESSORS AND CIRCUITRY, USE STATIC DISCHARGE EQUIPMENT, SUCH AS ANTI-STATIC WRIST STRAPS, WHEN ACCESSING INTERNAL COMPONENTS.
5. REPLACE MALFUNCTIONING COMPONENTS ONLY WITH THOSE COMPONENTS BY THE MANUFACTURE; INTRODUCTION OF SECOND-SOURCE ICs OR OTHER NONAPPROVED COMPONENTS MAY DAMAGE THE PRODUCT AND VOID ANY APPLICABLE EPSON WARRANTY.

PREFACE

This manual describes basic functions, theory of electrical and mechanical operations, maintenance and repair procedures of LX-300+. The instructions and procedures included in here are intended for the experienced repair technicians, and close attention should be given to the precautions on the preceding page. Chapters are organized as follows:

CHAPTER 1. PRODUCT DESCRIPTIONS

Provides a general overview and specifications of the product.

CHAPTER 2. OPERATING PRINCIPLES

Describes the theory of electrical and mechanical operations of the product.

CHAPTER 3. TROUBLESHOOTING

Provides the step-by-step procedures for troubleshooting.

CHAPTER 4. DISASSEMBLY AND ASSEMBLY

Describes the step-by-step procedures for disassembling and assembling the product.

CHAPTER 5. ADJUSTMENT

Provides adjusting procedures.

CHAPTER 6. MAINTENANCE

Provides preventive maintenance procedures.

APPENDIX

Provides the following addition information for reference:

- Connector Summary
- Parts List
- Exploded Diagrams
- Component Layout
- Circuit Schematics

Revision Status

Revision	Date of Issue	Description
A	May 11, 2000	First Release

Contents

Chapter 1 Product Description

1.1 Features	9
1.2 Printing Specification	10
1.2.1 Printing Specification	10
1.2.2 Paper Feeding	13
1.2.3 Electrical Specification	14
1.2.4 Environmental Condition	14
1.2.5 Reliability	14
1.2.6 Ribbon Cartridge	14
1.2.7 Safety Approvals	15
1.2.8 CE Marking	15
1.2.9 Acoustic noise:	15
1.2.10 Printable Area	16
1.3 Interface Specifications	19
1.3.1 Parallel Interface (Forward Channel)	19
1.3.2 Parallel Interface (Reverse Channel)	21
1.3.3 Serial Interface	22
1.3.4 Interface Selection	23
1.3.5 Prevention Hosts from Data Transfer Time-out	23
1.3.6 IEEE1284.4 protocol	23
1.4 Operation	24
1.4.1 Control Panel	24
1.4.1.1 Switches	24
1.4.1.2 LED	25
1.4.1.3 Buzzer	25
1.4.2 Functions	26
1.4.2.1 Usual Operation	26
1.4.2.2 Operation at Power-on	26
1.4.2.3 Default Setting	26
1.4.2.4 Bi-d. Adjustment	28
1.4.3 Errors	28
1.5 Control codes	29
1.5.1 ESC/P2	29

1.5.2 IBM 2390 Plus Emulation	30
1.5.3 Bi-Directional Commands	31
1.5.3.1 Reply Printer Status	33
1.5.3.2 Packet commands	34
1.6 Initialization	35
1.7 Paper Specifications	36
1.8 Physical Specifications	39
1.9 Accessories	40

Chapter 2 Operating Principles

2.1 Overview	42
2.2 Printer Mechanism (M-3M10)	43
2.2.1 Printhead	44
2.2.1.1 Buzzer Function	44
2.2.2 Carriage Mechanism	45
2.2.2.1 High speed skip method	47
2.2.3 Ribbon Mechanism	47
2.2.3.1 Ink Ribbon Shifting Mechanism	47
2.2.3.2 Color Ribbon Driving Mechanism (Option)	47
2.2.4 Platen Gap Adjustment Mechanism	49
2.2.5 Paper Feed Mechanism	50
2.2.5.1 Page Length Measurement	51
2.2.6 Release Mechanism	52
2.2.7 Other Special Functions	52
2.2.7.1 Energy saving mode	52
2.2.7.2 Quiet Mode	52
2.3 Electric Circuit Operating Principles	53
2.3.1 MAIN Board (Control Board) Electric Circuit	53
2.3.2 C294PSB / C294PSE Board	54
2.3.2.1 Electric Circuit	54

Chapter 3 Troubleshooting

3.1 Overview	56
3.2 Troubleshooting	57
3.2.1 Initialization Check	57
3.2.2 Check Performance By Self-Check Function	57
3.2.2.1 Indicator LED	57
3.2.3 Identify Problems From Symptoms	58
3.2.4 Unit and Parts Check	61
3.2.4.1 Printhead Check	61
3.2.4.2 Motor Check	62
3.2.4.3 Sensor Check	62
3.2.4.4 Printhead Driver Check	63

Chapter 4 Disassembly and Assembly

4.1 Overview	65
4.1.1 Precautions	65
4.1.2 Tools	65
4.1.3 Service Checks After Repair	66
4.2 Disassembly and Assembly	67
4.2.1 Printhead Removal	68
4.2.2 Upper Housing Removal	69
4.2.3 Printer Mechanism Removal	70
4.2.4 Board Assembly and Panel Removal	71
4.2.5 C294MAIN Board Assembly Removal	71
4.2.6 P/S Board Assembly Removal	72
4.2.7 Printer Mechanism Disassembly	73
4.2.7.1 CR Motor Assembly Removal	73
4.2.7.2 Platen Removal	74
4.2.7.3 Carriage Unit Removal	75
4.2.7.4 Ribbon Feed Mechanism Removal	76
4.2.7.5 RPE Sensor Removal	77
4.2.7.6 BPE Sensor Removal	77
4.2.7.7 HP Sensor Removal	77
4.2.7.8 PG Sensor Removal	78
4.2.7.9 Release Lever Position Sensor Removal	78
4.2.7.10 PF Motor Assembly Removal	79
4.2.7.11 Paper Feed Mechanism Disassembly	79

4.2.7.12 Paper Guide Removal	81
------------------------------------	----

Chapter 5 Adjustment

5.1 Overview	83
5.1.1 Platen Gap Adjustment	83
5.1.2 Bi-D Adjustment	84

Chapter 6 Maintenance

6.1 Maintenance	89
6.1.1 Cleaning	89
6.1.2 Lubrication	89

Chapter 7 Appendix

7.1 Connector Summary	94
7.2 Parts List	97
7.3 Exploded Diagrams	100
7.4 Component Layout	102
7.5 Circuit Schematics	103

CHAPTER

1

PRODUCT DESCRIPTION

1.2 Printing Specification

1.2.1 Printing Specification

- Print method: Impact dot matrix
- Number of pins: 9 pins
- Print pin arrangement: 9x1
- Print pin diameter: 0.29 mm (0.0114 inch)
- Color (Option): Black, Magenta, Cyan, Yellow
- Print direction: Bi-direction with logic seeking
- Print speed and printable columns:

Table 1-1. Print Speed and Printable Columns

Printing mode	Character pitch (cpi)	Printable columns	Printing speed (cps)
High speed draft	10	80	300
	12	96	337
	15	120	337
High speed draft condensed	17	137	321
	20	160	300
Draft	10	8-	225
	12	96	270
	15	120	225
Draft condensed	17	137	191
	20	160	225
Draft emphasized	10	80	112

Table 1-1. Print Speed and Printable Columns

Printing mode	Character pitch (cpi)	Printable columns	Printing speed (cps)
NLQ	10	80	56
	12	96	67
	15	120	56
	17	137	47
	20	160	56

NOTE: When the power supply voltage drops to the lower limit, the printer stops printing and then starts printing the rest on the line more slowly than before.

- Resolution:

Table 1-2. Resolution

Printing mode	Horizontal density (dpi)	Vertical density (dpi)	Adjacent dot print
High speed draft	90	72	No
Draft	120	72	No
Draft condensed	240	72	No
Draft emphasized	120	72	Yes
NLQ	240	144	No
Bit image	60, 72, 80, 90 or 120	72	Yes
	120 or 240	72	No

- Control code: ESC/P and IBM 2380 Plus emulation (Refer to 1.5 "Control codes")

□ Character tables:

- Standard version (13 character table)

Italic table	PC437 (US, Standard Europe)
PC850 (Multilingual)	PC860 (Portuguese)
PC863 (Canadian-French)	PC865 (Nordic)
PC861 (Icelandic)	BRASCII
Abicomp	Roman 8
ISO Latin 1	PC858
ISO 8859-15	

- NLSP version (38 character tables)

Italic table	PC437 (US, Standard Europe)
PC850 (Multilingual)	PC437 Greek
PC853 (Turkish)	PC855 (Cyrillic)
PC852 (East Europe)	PC857 (Turkish)
PC866 (Russian)	
PC869 (Greek)	MAZOWIA (Poland)
Code MJK (CSFR)	ISO 8859-7 (Latin / Greek)
ISO Latin 1T (Turkish)	Bulgaria (Bulgarian)
PC 774 (LST 1283:1993)	Estonia (Estonia)
ISO 8859-2	PC 866 LAT. (Latvian)
PC 866 UKR (Ukrania)	PC860 (Portuguese)
PC 861 (Icelandic)	PC865 (Nordic)
PC APTEC (Arabic)	PC708 (Arabic)
PC 720 (Arabic)	PCAR864 (Arabic)
PC863 (Canadian-French)	Abicomp
BRASCII	Roman 8
ISO Latin 1	Hebrew 7* ¹
Hebrew 8* ¹	PC862 (Hebrew)* ¹
PC858	IAO8859-15
PC771 (Lithuania)	

NOTE: *1: This item is not displayed on a default setting mode. Do not describe this in the manual.

□ International character sets: 13 countries

U.S.A	France	Germany
U.K.	Denmark 1	Sweden
Italy	Spain 1	Japan
Norway	Denmark 2	Spain 2
Latin America		

NOTE: The international and legal characters are the following 12 codes;
23H, 24H, 40H, 5BH, 5CH, 5DH, 5EH, 60H, 7BH, 7CH, 7DH, 7EH.

□ Typeface

- Bit map fonts:

EPSON Draft	10cpi, 12cpi, 15cpi
EPSON Roman	10cpi, 12cpi, 15cpi, Proportional
EPSON Sans serif	10cpi, 12cpi, 15cpi, Proportional
EPSON OCR-B	10cpi* ¹

NOTE: *1: Do not describe in manual.

□ Bar codes

EAN-13	EAN-8	Interleaved 2 of 5
UPC-A	UPC-E	Code 39
Code 128	POSTNET	Coda bar (NW-7)* ¹
Industrial 2 of 5 * ¹	Matrix 2 of 5 * ¹	

NOTE: *1: Do not describe in manual.

- Character tables and typefaces:

Table 1-3. Character Tables and Typefaces

	Character table	Bitmap font
Standard version	Italic table PC 437 (US, Standard Europe)	EPSON Draft EPSON Roman EPSON Sans serif EPSON OCR-B
	PC 850 (Multilingual) BRASCII PC 860 (Portuguese) Abicomp PC 863(Canadian-French) Roman 8 PC 865 (Nordic) ISO Latin 1 PC 861 (Icelandic) PC 858 ISO 8859-15	EPSON Draft EPSON Roman EPSON Sans serif

Table 1-3. Character Tables and Typefaces

	Character table	Bitmap font
NLSP version	Italic table PC 437(US, Standard Europe)	EPSON Draft EPSON Roman EPSON Sans serif EPSON OCR-B
	PC 860(Portuguese) PC 850 (Multilingual) PC 865(Nordic) PC 861 (Icelandic) BRASCII PC863 (Canadian-French) Roman 8 PC437 (Greek) Abicomp PC 855 (Cyrillic) ISOLatin1 PC 857 (Turkish) PC 853 (Turkish) PC 869 (Greek) PC 852 (East Europe) Code MJK (CSFR) PC 866 (Russian) ISO Latin 1T (Turkish) MAZOWIA (Poland) PC774 (LST 1283: 1993) ISO 8859-7 (Latin/Greek) ISO 8859-2 PC 866 UKR (Ukrania) Bulgaria (Bulgarian) PC 708 (Arabic) Estonia (Estonia) PCAR864 (Arabic) PC 866 LAT. (Latvian) Hebrew 8*1 PC APTEC (Arabic) PC 858 PC 720 (Arabic) PC771 (Lithuania) Hebrew7*1 PC862 (Hebrew)*1 ISO 8859-15	EPSON Draft EPSON Roman EPSON Sans serif

NOTE: ESC R command is effective on all the character tables.

NOTE: *1: These items are not displayed in the default setting mode. Do not describe in the manual.

1.2.3 Electrical Specification

- 120 V version
 - Rated voltage: AC 120V
 - Input voltage range: AC 99 to 132 V
 - Rated frequency range: 50 to 60 Hz
 - Input frequency range: 49.5 to 60.5 Hz
 - Rated current: 0.6A (max. 1.4A)
 - Power consumption: approx. 23W (ISO/IEC 10561 Letter pattern)
 - Insulation resistance: 10M Ω min.
(between AC line and chassis, DC 500V)
 - Dielectric strength: AC 1000 Vrms. 1 min. or
AC 1200 Vrms. 1 sec.
(between AC line and chassis)
- 230 V version
 - Rated voltage range: AC 220 to 240 V
 - Input voltage range: AC 198 to 264 V
 - Rated frequency range: 50 to 60 Hz
 - Input frequency range: 49.5 to 60.5 Hz
 - Rated current: 0.3 A (max. 0.7A)
 - Power consumption: approx. 23W (ISO/IEC10561 Letter pattern)
 - Insulation resistance: 10M Ω min.
(between AC line and chassis, DC 500V)
 - Dielectric strength: AC 1500 Vrms. 1 min.
(between AC line and chassis)

1.2.4 Environmental Condition

- Temperature: 5 to 35 °C (operating*¹)
15 to 25 °C (operating*^{1,*2})
-30 to 60 °C (non-operating)
- Humidity: 10 to 80% RH (operating*¹)
30 to 60% RH (operating*^{1,*2})
0 to 85% RH (non-operating)
- Resistance to shock: 1 G, within 1ms (operating)
2 G, within 2ms (non-operating*³)
- Resistance to vibration: 0.25 G, 10 to 55 Hz (operating)
0.50 G, 10 to 55 Hz (non-operating*³)

*1: without condensation

*2: during printing on multi part paper, envelop, card, or label

*3: without shipment container

1.2.5 Reliability

- Total print volume: 12 million lines (except printhead)
- MTBF: 6000 POH
- Printhead life: 400 million strokes / wire (Black)
100 million strokes / wire (Color)

1.2.6 Ribbon Cartridge

- Type: Fabric
Color: Black
Ribbon life: 3 million characters
(Draft 10 cpi, 14 dots/character)
- Type: Fabric
Color: Black, Magenta, Cyan and Yellow
Ribbon life:
 - Black 1 million characters (Draft 10 cpi, 14 dots/character)
 - Magenta 0.7 million characters (Draft 10 cpi, 14 dots/character)
 - Cyan 0.7 million characters (Draft 10 cpi, 14 dots/character)

- Yellow 0.5 million characters (Draft 10 cpi, 14 dots/character)

1.2.7 Safety Approvals

120 V version

- Safety standards: UL1950
CSA C22.2 No. 950
- EMI: FCC part15 subpart B class B
CSA C108.8 class B

230 V version

- Safety standards: EN60950 (VDE)
- EMI: EN55022 (CISPR pub.22) class B
AS/NZS 3548 class B

1.2.8 CE Marking

230 V version and UPS version

- Low voltage directive 73/23/EEC: EN60950
- EMC Directive 89/336/EEC: EN55022 class B
EN61000-3-2
EN61000-3-3
EN50082-1
IEC801-2
IEC801-3
IEC801-4

1.2.9 Acoustic noise:

Level: 49 dB(A) (ISO 7779 pattern)

1.2.10 Printable Area

- Cut sheets

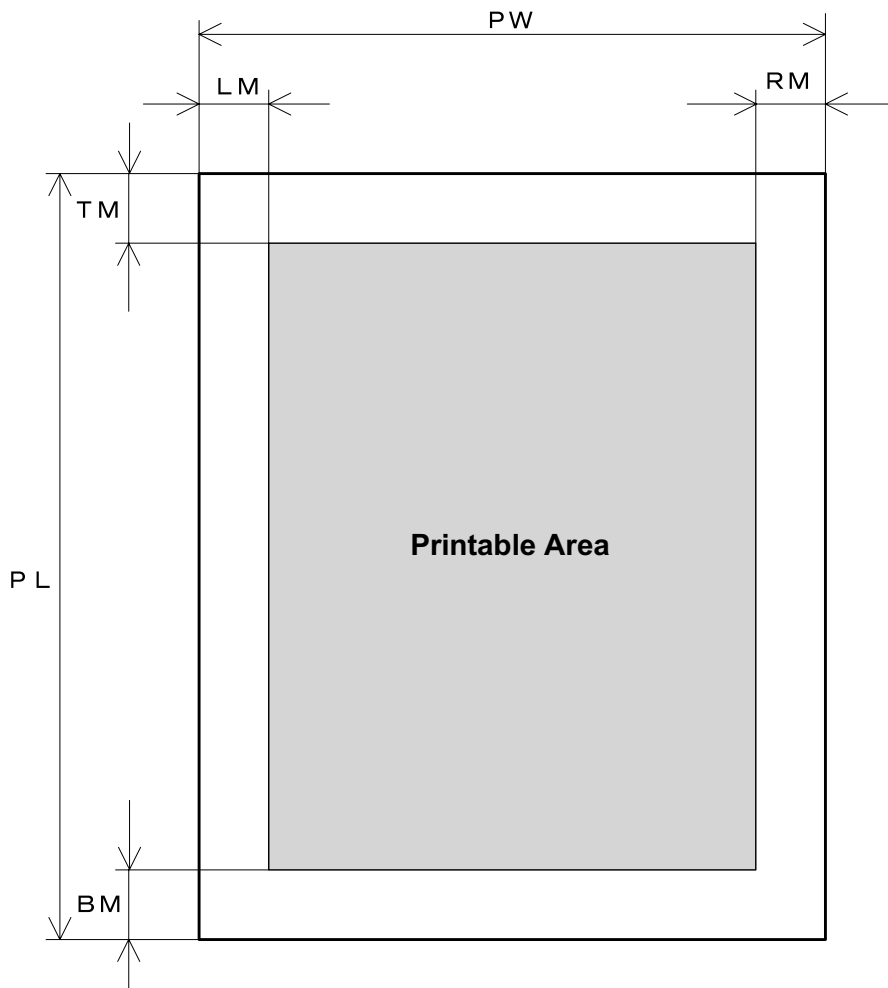

Figure 1-2. Printable Area for Cut Sheet

Table 1-6. Printable Area for Cut Sheet

	Single Sheet	Multi Part
PW (Width)	Refer to 1.7 "Paper Specifications"	Refer to 1.7 "Paper Specifications"
PL (Length)	Refer to 1.7 "Paper Specifications"	Refer to 1.7 "Paper Specifications"
LM (Left Margin)	When PW≤229 mm: 3 mm or more When PW=257 mm: 24mm or more	When PW≤229 mm: 3 mm or more When PW=257 mm: 24mm or more
RM (Right Margin)	When PW≤229 mm: 3 mm or more When PW=257 mm: 24mm or more	When PW≤229 mm: 3 mm or more When PW=257 mm: 24mm or more
TM (Top Margin)	4.2 mm or more	4.2 mm or more
BM (Bottom Margin)	4.2 mm or more	4.2 mm or more

NOTE: The maximum horizontal printable area is 203.2mm.

□ Envelop

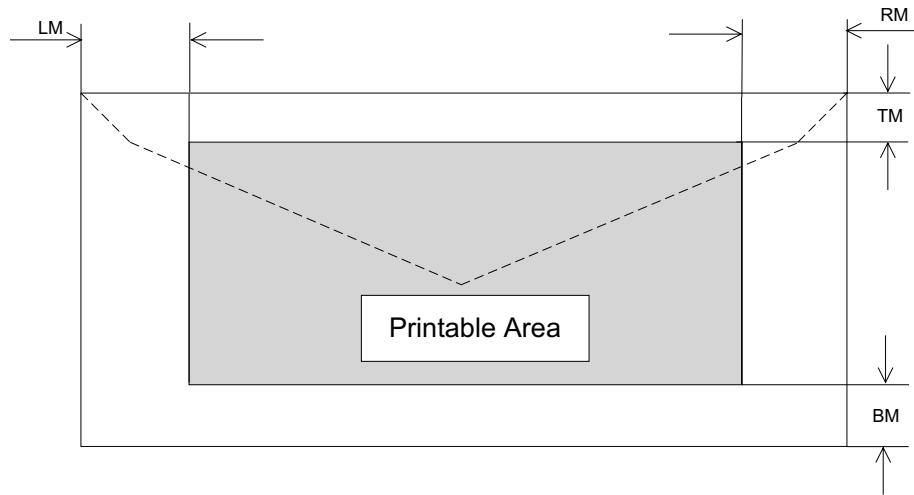

Figure 1-3. Printable Area for Envelop

Table 1-7. Printable Area for Envelop

	Envelope Printable Area
PW (Width)	Refer to 1.7 "Paper Specifications"
PL (Length)	Refer to 1.7 "Paper Specifications"
LM (Left Margin)	3 mm or more
RM (Right Margin)	3 mm or more
TM (Top Margin)	4.2 mm or more
BM (Bottom Margin)	4.2 mm or more

NOTE: The maximum horizontal printable area is 203.2mm.

□ Continuous paper

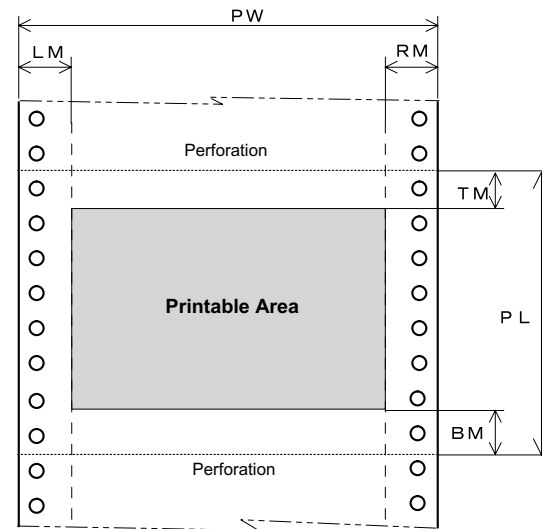

Figure 1-4. Printable Area for Continuous Paper

Table 1-8. Printable Area for Continuous Paper

	Continuous Paper
PW (Width)	Refer to 1.7 "Paper Specifications"
PL (Length)	Refer to 1.7 "Paper Specifications"
LM (Left Margin)	When PW<=254mm: 13 mm or more When PW=254 mm: 24mm or more
RM (Right Margin)	When PW<=254mm: 13 mm or more When PW=254 mm: 24mm or more
TM (Top Margin)	4.2 mm or more
BM (Bottom Margin)	4.2 mm or more

NOTE: The maximum horizontal printable area is 203.2mm.

□ Roll paper

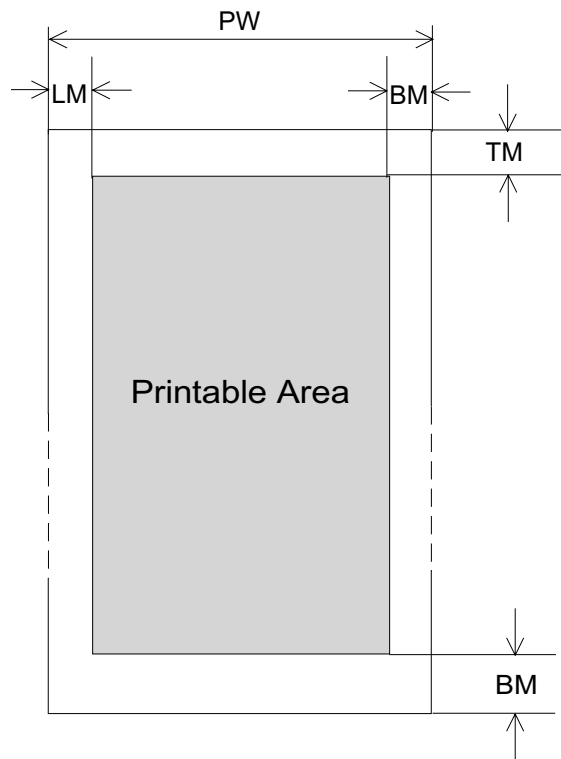

Figure 1-5. Printable Area for Roll Paper

Table 1-9. Printable Area for Roll Paper

	Continuous Paper
PW (Width)	Refer to 1.7 "Paper Specifications"
PL (Length)	Refer to 1.7 "Paper Specifications"
LM (Left Margin)	3 mm or more
RM (Right Margin)	3 mm or more
TM (Top Margin)	4.2 mm or more
BM (Bottom Margin)	4.2 mm or more

1.3 Interface Specifications

LX-300+ provides bi-directional 8 bit parallel interface and serial interface. Optional interface board is not supported on this model.

1.3.1 Parallel Interface (Forward Channel)

- Transmission mode: 8 bit parallel
IEEE-1284 compatibility mode
- Adaptable connector: 57-30360 (Amphenol) or equivalent
- Synchronization: -STROBE pulse
- Handshaking: BUSY and -ACKLG signals
- Signal level: TTL compatible
(IEEE-1284 level 1 device)

Table 1-10. Parameter

Parameter	Minimum	Maximum	Condition
V_{OH}^*	--	5.5V	
V_{OL}^*	-0.5V	--	
I_{OH}^*	--	0.32mA	$V_{OH}=2.4V$
I_{OL}^*	--	12mA	$V_{OL}=2.4V$
C_O	--	50pF	
V_{IH}	--	2.0V	
V_{IL}	0.8V	--	
I_{IH}	--	0.32mA	$V_{IH}=2.0V$
I_{IL}	--	12mA	$V_{IL}=0.8V$
C_I	--	50pF	

* Logic-H signal is 2.0V or lower when the printer is off and the signal is 3.0V or higher when the printer is on. The receiver has impedance which is equivalent to 7.5 k Ω .

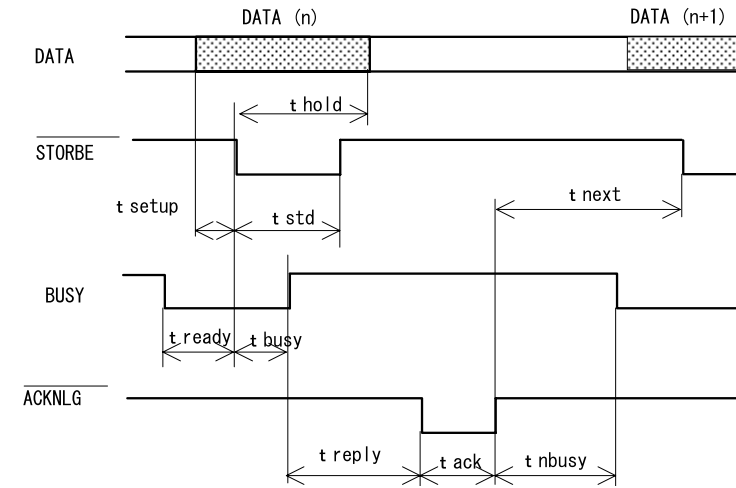

Figure 1-6. Data Transmitting Timing

Table 1-11. Maximum & Minimum Timings for Data Transmission

Parameter	Minimum	Maximum
t_{setup}	500 nsec	--
t_{hold}	500 nsec	--
t_{stb}	500 nsec	--
t_{ready}	0	--
t_{busy}	--	500 nsec
t_{reply}	--	--
t_{ack}	500 nsec	10 us
t_{nbusy}	0	--
t_{next}	0	--
t_{tout}^*	--	120 nsec
t_{tin}^{**}	--	200 nsec

* Rise and fall time of output signals

** Rise and fall time of input signals.

- BUSY signal is active (HIGH level) under the conditions below:
 - In the process of receiving data
 - In the condition of being input buffer full
 - In the condition of being -INT signal active (low level)
 - During hardware initialization
 - In the condition of being -ERROR or PE signal is active (low level, high level, respectively)
 - In the self test mode
 - In the adjustment mode
 - In the default-setting mode
- -ERROR signal is active (low level) under the conditions below:
 - In the condition of a paper-out error
 - In the condition of a release lever error
- PE signal is active (high level) under the condition below:
 - In the condition of a paper-out error

Table 1-12. Connector Pin Assignment and Signals

Pin No.	Signal Name	Return GND Pin	In/Out	Functional Description
1	-STROBE	19	In	Strobe pulse. Input data is latched at falling edge of the signal.
2	DATA1	20	In	Parallel input data to the printer. bit0:LSB
3	DATA2	21	In	bit1
4	DATA3	22	In	bit2
5	DATA4	23	In	bit3
6	DATA5	24	In	bit4
7	DATA6	25	In	bit5

Table 1-12. Connector Pin Assignment and Signals

Pin No.	Signal Name	Return GND Pin	In/Out	Functional Description
8	DATA7	26	In	bit6
9	DATA8	27	In	bit7:MSB
10	-ACKNLG	28	Out	This signal (negative pulse) indicates that the printer has received data and is ready to accept next one.
11	BUSY	29	Out	This signal's high level means that the print is not ready to accept data.
12	PE	28	Out	This signal's high level means that the printer is in a state of paper-out error.
13	SLCT	28	Out	Always at high level when the printer is powered on.
14	-AFXT	30	In	Not used.
31	-INIT	30	In	This signal's negative pulse initializes printer.
32	-ERROR	29	Out	This signal's low level means the printer is in a state of error.
36	-SLIN	30	In	Not used.
18	Logic H	--	Out	This line is pulled up to +5V through 3.9 kΩ resistor.
35	+5V	--	Out	This line is pulled up to +5V through 1.0 kΩ resistor.
17	Chassis	--	--	Chassis GND.
16, 33, 19-30	GND	--	--	Signal GND.
15, 34	NC	--	--	Not connected.

NOTE: In/Out shows the direction of signal flow from the printer's point of view.

1.3.2 Parallel Interface (Reverse Channel)

- Transmission mode: IEEE-1284 nibble mode
- Adaptable connector: See 1.3.1 "Parallel Interface (Forward Channel)"
- Synchronization: Refer to the IEEE-1284 specification
- Handshaking: Refer to the IEEE-1284 specification
- Signal level: IEEE-1284 level 1 device
See 1.3.1 "Parallel Interface (Forward Channel)"
- Data transmission timing: Refer to the IEEE-1284 specification
- Extensibility request: The printer responds to the extensibility request affirmatively, when the request is 00H or 004H, which means;
 - 00H: Request for nibble mode of reverse channel transfer
 - 04H: Request device ID in nibble mode of reverse channel transfer
- Device ID: The printer sends following device ID string when it is requested.
 - When IEEE1284.4 is enabled;

Table 1-13.

[00H][4EH]
MFG: EPSON;
CMD: ESCPL2,PRPXL24,BDC,D4;
MDL: LX-300+;
CLS: PRINTER;
DES: EPSON[SP]LX-300+;

- When IEEE1284.4 is disabled;

Table 1-14.

[00H][4BH]
MFG: EPSON;
CMD: ESCPL2,PRPXL24,BDC;
MDL: LX-300+;
CLS: PRINTER;
DES: EPSON[SP]LX-300+;

Table 1-15. Connector Pin Assignment and Signals

Pin No.	Signal Name	Return GND Pin	In/Out	Functional Description
1	HostClk	19	In	Host clock signal.
2	DATA1	20	In	Parallel input data to the printer. bit0:LSB
3	DATA2	21	In	bit1
4	DATA3	22	In	bit2
5	DATA4	23	In	bit3
6	DATA5	24	In	bit4
7	DATA6	25	In	bit5
8	DATA7	26	In	bit6
9	DATA8	27	In	bit7:MSB
10	PtrClk	28	Out	Printer clock signal.
11	PtrBusy/ DataBit-3,7	29	Out	Printer busy signal and reverse channel transfer data bit 3 or 7.
12	AckDataReq/ DataBit-2,6	28	Out	Acknowledge data request signal and reverse channel transfer data bit 2 or 6.
13	Xflag/ DataBit-1,5	28	Out	X-flag signal and reverse channel transfer data bit 1 or 5.
14	HostBusy	30	In	Host busy signal.
31	-INIT	30	In	Not used.
32	-DataAvail/ DataBit-0,4	29	Out	Data available signal and reverse channel transfer data bit 0 or 4.
36	1284-Active	30	In	1284 active signal.
18	Logic-H	--	Out	This line is pulled up to +5V through 3.9 kΩ resistor.

Table 1-15. Connector Pin Assignment and Signals

Pin No.	Signal Name	Return GND Pin	In/Out	Functional Description
35	+5V	--	Out	This line is pulled up to +5V through 1.0 k Ω resistor.
17	Chassis	--	--	Chassis GND.
16, 33, 19-30	GND	--	--	Signal GND.
15, 34	NC	--	--	Not connected.

* In/Out shows the direction of signal flow from the printer's point of view.

1.3.3 Serial Interface

- Synchronization: Asynchronous
- Signal level: EIA-232D
 MARK (logical 1): -3V to -25V
 SPACE (logical 0): +3V to +25V
- Word length: Start bit: 1 bit
 Data bit: 8 bit
 Parity bit: Odd, Even, Non, Ignore
 Stop bit: 1 bit or more
- Baud rate: 300, 600, 1200, 2400, 4800, 9600 or 19200 bps
- Handshaking: DTR signal and XON/XOFF
 DTR=MAEK, XOFF: indicates that the printer cannot receive data.
 DTR=MARK, XON: indicates that the printer is ready to receive data.

NOTE: The DTR signal is MARK and XOFF code (DC3, 13H) is transmitted when the rest of the input buffer becomes 256 bytes. The DTR signal is SPACE and XON code (DC1, 11H) is transmitted when the rest of the input buffer is regained 256 byte.

- Error handling: Parity error is only detected. Overrun error and framing error are ignored.

- Connector: 25 pin subminiature D-shell connector (female)

Table 1-16. Connector Pin Assignment and Signals

Pin No.	Signal Name	In/Out	Functional Description
2	TXD	Out	Transmit data.
20	DTR	Out	Indicates that the printer is ready to receive data or not.
11	REV	Out	Connected directly to the DTR signal.
4	RTS	Out	Request to send. Always SPACE level when the printer is powered on. Pulled up to +12V via 4.7K Ω resistor.
3	RXD	In	Receive data.
7	Signal GND	--	Signal GND
1	Chassis GND	--	Chassis GND
other	NC	--	Not used. Not connected.

* In/Out shows the direction of signal flow from the printer's point of view.

1.3.4 Interface Selection

The printer has 2 interfaces; the parallel interface and serial interface. These interfaces are selected manually by Default Setting or selected automatically.

Manual Selection

One of 2 interfaces can be selected by Default setting.

Automatic Selection

The automatic interface selection is enabled by Default Setting. In this automatic interface selection mode, the printer is initialized to the idle state scanning which interface receives data when it is powered on. Then the interface that receives data first is selected. When the host stops data transfer and the printer is in stand-by state for the seconds specified by Default Setting, the printer is returned to the idle state. As long as the host sends data or the printer interface is in busy state, the selected interface is let as it is.

Interface State and Interface Selection

When the parallel interface is not selected, the interface gets into a busy state. When the serial interface is not selected, the interface sends XOFF and sets the DTR signal MARK. When the printer is initialized or returned to the idle state, the parallel interface got into a ready state, the serial interface sends XON and sets the DTR SPACE. Caution that the interrupt signal such as a -INIT signal on the parallel interface is not effective while that interface is not selected.

Auto:

Communication is carried out in the conventional mode until a magic string (1284.4 synchronous commands) is received. By receiving a magic string, communication in IEEE1284.4 packet mode is started.

Off:

Communication is carried out in the conventional mode. A magic string (284.4 synchronous commands) is discarded.

NOTE: *The packet protocol of IEEE1284.4 allows a device to carry on multiple exchanges or conversations which contain data and/or control information with another device at the same time across a single point-to-point link.*

The protocol is not, however, a device control language. It does provide basic transport-level flow control and multiplexing services.

The multiplexed logical channels are independent of each and blocking of one has no effect on the others. The protocol operates over IEEE1284.

1.3.5 Prevention Hosts from Data Transfer Time-out

Generally, hosts abandons data transfer to peripherals when a peripheral is in busy state for dozens of seconds continuously. To prevent hosts from this kind of time-out, the printer receives data very slowly, several bytes per minute, even if the printer is in busy state. This slowdown is started when the rest of the input buffer becomes several hundreds of bytes. At last, when the input buffer is full, the printer is in busy state continuously.

1.3.6 IEEE1284.4 protocol

The packet protocol described by IEEE1284.4 is supported on the parallel I/F. Two function modes of IEEE1284.4 protocol, "Off" and "Auto" are available, and one of them is selected according to the value of Default setting. (See 1.4.2.3 "Default Setting")

1.4 Operation

1.4.1 Control Panel

4 switches and 4 LEDs are on the panel as shown below.

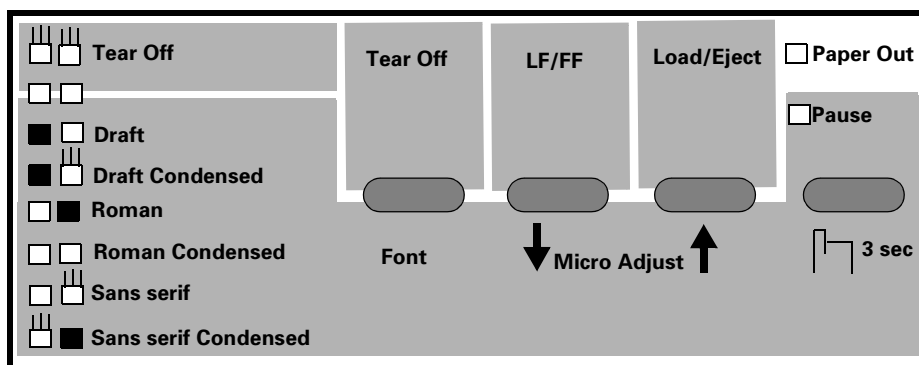

□ : LED On □ (with lines) : LED Blinks ■ : LED Off

Figure 1-7. Control Panel

1.4.1.1 Switches

- Operation in normal mode
In normal mode, pressing panel switches executes following function;

Table 1-17. Operation in Normal Mode

Switch	Function
Pause	-Alternates printing and non-printing status. -Enables Micro Adjustment function and Font selection, holding it down for 3 seconds.
Load/Eject	-Loads or ejects paper. -Execute micro feed forward, when this function is enabled.
LF/FF	-Executes line feed, pressing it shortly. -Executes form feed, holding it down for a few seconds. -Executes micro feed backward, when this function is enabled.
Tear Off	-Advances continuous paper to the Tear-off position. -Select font, when this function is enabled.

- Operation at power on
Turning the printer on while pressing panel switches executes the functions below;

Table 1-18. Operation at Power On

Switch	Function
Load/Eject	NLQ self test
LF/FF	Draft self test
Tear Off	Default setting
Load/Eject & LF/FF	Data dump
Load/Eject & LF/FF & Pause	Clear EEPROM
Tear Off & Load/Eject & LF/FF	Clear EEPROM for Diving Line count for ribbon change timing.
Pause	Bi-d adjustment
The others	Not available

- Operation in default setting mode
The following switches are used in default setting mode;

Table 1-19. Operation at Power On

Switch	Function
Tear Off	Changes the setting.
LF/FF	Selects the Menu.
The others	Not available.

1.4.1.2 LED

- Indication in normal mode

Table 1-20. Indication in normal mode

Printer Status	LED		
	Pause* ¹	Paper Out* ²	Font
Pause	On	---	---
Paper out error	On	On	---
Release lever error	On	---	---
Paper eject warning	On	Blink	---
Micro Adjust	Blink	---	---
Tear off	---	---	*3
Font selection	---	---	*3
Fatal error	Blink	Blink	Blink

***1 Pause (Orange)**

- It is on when the printer is paused, and it is off when the printer is not paused.
- It blinks when Micro Adjust is enabled.

***2 Paper Out (Red)**

- It is on when the printer is in the Paper out status, and it is off when the printer is out of this status.

***3 Font (Green)**

- The status of Font selection is displayed by 2 Font LEDs when continuous paper is out of the Tear-off position.

- Both LEDs blink when continuous paper is in the Tear-off position.

- : Draft
- ★: Draft Condensed
- : Roman
- : Roman Condensed
- ★: Sans serif
- ★■: Sans serif Condensed
- ★★: Tear Off

(□: LED On, ■: LED Off, ★: LED Blinks)

1.4.1.3 Buzzer

- Paper out error: Beeper sounds (...)*
- Release lever operation: Beeper sounds(-----)*
- Illegal panel operation: Beeper sounds (.)*

*The description (.) and (-) in the above shows how the beeper sounds.

(.): Beeper sounds approx. 100ms and interval is approx. 100ms.

(-): Beeper sounds approx. 500ms and interval is approx. 100ms.

1.4.2 Functions

1.4.2.1 Usual Operation

- Pause
 - This switch alternates printer activity between printing and non-printing.
 - By holding it down over 3 seconds when the printer is in the stand by state, the Micro Adjust function is enabled. By pressing it again, this function is disabled.
- Load/Eject
 - Pressing it loads out sheet or continuous paper when the printer is out of paper.
 - Pressing it ejects out sheet to the stacker or continuous paper to the paper park.
- LF/FF
 - Pressing it shortly executes line feed.
 - Holding it down for a few seconds executes form feed when continuous paper is used, or ejects cut sheet to the stacker when cut sheet is used.
- Tear Off
 - When continuous paper is used, pressing it moves a page to the Tear-off position. And pressing it again moves a next page to the TOF position.
- Font
 - Pressing it selects one of the following fonts when Micro Adjust is enabled;
Draft, Draft Condensed, Roman, Roman Condensed, Sans serif, Sans serif Condensed
- Micro Adjust
 - Micro Adjust ↓/↑ switches is effective when the Micro Adjust function is enabled by Pause switch.
 - Pressing the Micro Adjust ↓/↑ switches executes micro feed backward and forward by 0.118 mm (1/216 inch).
 - The TOF adjustment is enabled in the TOF position after loading, and the Tear-off adjustment is enabled in the Tear-off position.

1.4.2.2 Operation at Power-on

- Self test
 - Prints the self test pattern. To cancel it, make printer pause and turn off the power.
- Default setting
 - Starts the default setting mode. See 1.4.2.3 "Default Setting".
- Data Dump
 - Starts the data dump mode, in which all the input data are printed as hexadecimal numbers and corresponding characters.
- Clear EEPROM
 - Resets the printer to the factory default setting, which is not always proper setting for each market demand.
(i.e. This function is for emergency.)
Clear Areal EEPROM data except 00H to 1FH.
- Clear EEPROM for Driving Line count for ribbon change timing.
 - Resets the diving Line count for ribbon change timing.
- Bi-d adjustment
 - Starts the Bi-d adjustment mode. See 1.4.2.4 "Bi-d. Adjustment".
- Demonstration
 - Not available.

1.4.2.3 Default Setting

There are some parameters that can be changed by users and will be referred at the time of initialization of the printer.

- Setting mode
 1. Enters the Default setting mode.
The method of selecting language for "Usage of this mode" is printed.
 2. Select language for "Usage of this mode" by LF/FF button.
Font LEDs show the language for "Usage of this mode" that is currently selected.
This section will be advanced one by one as the button is pressed and the On/Off/Blink/2-Blink of those three LEDs will also be changed according to the selection.

3. Press Tear Off button.
The current setting and the "Usage of this mode" by selected language will be printed on the paper set in the paper path at that time.
A print sample is shown in appendix A.
4. Select Menu by Tear Off button.
Font LEDs show the menu which is selected at that time. The selection will be advanced one by one as the button is pressed and the combination of those three LEDs status of On/Off/Blink/2-Blinks will be changed according to the selection.
5. Select setting value by LF/FF button.
Tear Off/ Bin LEDs and Paper Out LED show that menu's value by status of On/Off/Blink/2-Blinks. That value can be changed by pressing Tear Off/ Bin button and the LEDs status of On/Off/Blink/2-Blinks will be changed as the button is pressed.
6. When LF/FF button is pressed, the printer memorize the last setting value.
7. Repeat (4) to (6).
The other items can be changed in the same manner.
The menu selection will return to the first menu after the last menu selection is over.
8. Turn the printer off.
The setting is stored into non-volatile memory.

Table 1-21. Setting Menu

Item	Setting / Value *2
Page length for tractor	3 inch, 3.5 inch, 4 inch, 5.5 inch, 6 inch, 7 inch, 8 inch, 8.5 inch, <u>11 inch</u> , 70/6 inch, 12 inch, 14 inch, 17 inch
Skip over perforation	<u>OFF</u> , ON
Auto tear off	<u>OFF</u> , ON
Auto line feed	<u>OFF</u> , ON
Print direction	<u>Bi-d.</u> , Uni-d., Auto
Software	<u>ESC/P2</u> , IBM 2390 Plus
0 slash	<u>OFF</u> , ON

Table 1-21. Setting Menu

Item	Setting / Value *2
High speed draft	OFF, <u>ON</u>
I/F mode	<u>Auto</u> , Parallel, Option
Auto I/F wait time	<u>10 seconds</u> , 30 seconds
Parallel I/F bidirectional mode	OFF, <u>ON</u>
Packet mode	<u>Auto</u> , OFF
Auto CR (IBM 2390 Plus)	<u>OFF</u> , ON
A.G.M. (IBM 2390 Plus)	<u>OFF</u> , ON
Character table	Software version Italic, <u>PC437</u> , PC850, PC860, PC863, PC865, PC861, BARASCII, Abicomp, Roman8, ISO Latin 1, PC858, ISO 8859-15
	NLSP version Italic, <u>PC437</u> , PC850, PC437, Greek, PC853, PC855, PC852, PC857, PC864, PC866, PC869, MAZOWIA, Code MJK, ISO 8859-7, ISO Latin 1T, Bulgaria, PC774, Estonia, ISO 8859-2, PC 866 LAT., PC 866UKR, PC APTEC, PC708, PC720, PCAR 864, PC860, PC865, PC861, PC863, BRASCII, Abicomp, Roman8, ISO Latin 1, PC858, ISO 8859-15, PC771
International character set for Italic table	<u>Italic U.S.A.</u> , Italic France, Italic Germany, Italic, U.K., Italic Denmark 1, Italic Sweden, Italic Italy, Italic Spain 1
Manual feed wait time	1 second, <u>1.5 seconds</u> , 2 seconds, 3 seconds
Buzzer	OFF, <u>ON</u>
Auto CR (IBM 2380 Plus)*1	<u>OFF</u> , ON
IBM character table *1	<u>Table2</u> , Table1

NOTE: *1: This setting is effective when IBM 2380 Plus emulation is selected.

NOTE: Setting with underline mean the standard factory settings.

1.4.2.4 Bi-d. Adjustment

Bi-d. adjustment can be adjusted by users. Bi-d. adjustment method is as follows.

1. Turning the printer on while pressing Pause switch. The guide to adjust Bi-d alignment in this mode and the first alignment pattern will be printed.
2. Select the most closely aligned number by pressing LF/FF (↓) and Load/Eject (↑) switches.
Font LEDs and Pause LED show the pattern number which is selected at that time. The selection is advanced one by one as the switch is pressed, and the combination of On/Off/Blink of those three LEDs is also changed according to the selection.
3. Fix the selected number by pressing Tear Off switch.
Selected number is fixed and the next alignment pattern is printed.
4. Repeat step 2 to 3 until finishing Bi-d adjustment for NLQ mode.
Following adjustment is executed.
 - Bi-d. adjustment for high speed draft mode
 - Bi-d. adjustment for draft mode
 - Bi-d. adjustment for NLQ mode
5. Turn the printer off.
The setting is stored into non-volatile memory.

1.4.3 Errors

- Paper out error:
When the printer fails to feed a sheet, it goes a paper out error.
- Release lever error:
When release lever position is wrong, it goes a release lever error.
- Fatal errors:
Carriage control error and Power supply voltage error.

1.5 Control codes

1.5.1 ESC/P2

Table 1-22. ESC/P2

Classification	Operation	Command
General Operation	Initialize Printer	ESC@
	Unidirectional Printing	ESC U
	CSF Mode Control	ESC EM
Paper feeding	Form Feed	FF
	Line Feed	LF
	Line Spacing	ESC 0, ESC 2, ESC3, ESC A
	Carriage Return	CR
Page format	Page Length	ESC C, ESC C0, ESC (C
	Left / Right Margin	ESC Q, ESC1
	Top / Bottom Margin	ESC N, ESC O, ESC (c
	Define Unit	ESC (U
Print position motion	Horizontal Print Position	ESC\$, ESC¥
	Vertical Print Position	ESC (V, ESC (v
	Tab Horizontally	ESC D, HT
	Tab Vertically	ESC B, VT
	Advance paper	ESC J
Font selection	Typeface	ESC k, ESC x, ESC y
	Pitch	ESC P, ESC M, ESC g, ESC p
	Italic Font	ESC 4, ESC 5
	Bold Font	ESC E, ESC F
	Master Select	ESC!

Table 1-22. ESC/P2

Classification	Operation	Command
Font enhancement	Double-Width	ESC W, DC4, SO
	Condensed	DC2, SI
	Double-height	ESC w
	Double-Strike	ESC G, ESC H
	Super-/ Subscript	ESC T, ESC S
	Underline	ESC-
Spacing	Intercharacter Space	ESC Space
Character handling	Character Table	ESC t, ESC (t
	International Character	ESC R
	User-Defined Characters	ESC%, ESC &, ESC:
	Control code selection	ESC1
	Upper Control Codes	ESC6, ESC7
Bit image	8 pin Bit Image	ESC K, ESC L, ESC Y, ESC Z, ESC*
	9 pin Bit Image	ESC ^
Printing color	Select color	ESC r
Bar code	Bar code	ESC (B
Production	EEPOM write, etc.	ESC!

1.5.2 IBM 2390 Plus Emulation

Table 1-23. IBM 2390 Plus emulation

Classification	Operation	Command
General Operation	Nop	NUL, DC3
	Off Line	ESC j
	Buzzer	BEL
	Cancellation	CAN
	Select / Deselect	DC1, ESC Q
	Initialize Printer	ESC [K
	Unidirectional Printing	ESC U
	Select Auto Sheet Feeder	ESC [F
Paper feeding	Form Feed	FF
	Line Feed, Auto Line Feed	LF, ESC5
	Line Spacing	ESC A, ESC 0, ESC 1, ESC 2, ESC3
	Carriage Return	CR
	Reverse Line Feed	ESC]
Page format	Page Length	ESC C, ESC C0
	Left / Right Margin	ESC X
	Skip Over Perforation	ESC N, ESC O
	Set TOF	ESC 4
Print position motion	Horizontal Print Position	ESC d
	Initialize Tab Position	ESC R
	Tab Horizontally	ESC D, HT
	Tab Vertically	ESC B, VT
	Advance paper	ESC J

Table 1-23. IBM 2390 Plus emulation

Classification	Operation	Command
Font selection	Pitch	DC 2, ESC P, ESC:
	Bold Font	ESC E, ESC F
	Master Select	ESC I
	Print Quality	ESC [d
	Select Font and Pitch	ESC [I
Font enhancement	Double-Width	DC4, SO, ESC SO, ESC W
	Enlarge and Life Space	ESC [@
	Condensed	SI, ESC SI
	Double-Strike	ESC G, ESC H
	Super-/ Subscript	ESC T, ESC S
	Underline	ESC -
	Line / Score	ESC_
Spacing	Back Space	BS
	Space	SP
	Define Unit	ESC [¥
Character handling	Character Table	ESC 6, ESC 7, ESC [T
	Print Data as Characters	ESC ^, ESC ¥
Bit image	Bit Image	ESC K, ESC L, ESC Y, ESC Z
Bar code	Set up Bar code	ESC [f
	Transfer Bar code	ESC [p
Download	Download	ESC=(only Draft mode)

1.5.3 Bi-Directional Commands

- Reply printer ID

Reply printer ID: [ESC][SOH]@EJL[SP]ID[CR][LF]

The printer sends the following ID string in reply to this command.

Table 1-24.

```
@EJL[SP]ID[CR][LF]
MFG: EPSON;
CMD: ESCPL2,PRPXL24,BDC;
MDL: LX-300+;
CLS: PRINTER;
DES: EPSON[SP]LX-300+;
[FF]
```

- Enter / Exit Remote Mode

- Enter Remote Mode: [ESC](R[08H][00H][00H]REMOTE1
- Exit Remote Mode: [ESC][NUL][00H][00H]

- Remote Commands

- Change Printer Settings: XX[nL][nH][00H][m1]...[mx]
- Reply Printer Settings: XX[nL][nH][01H][m1]...[mx]

XX is a string of 2 ASCII characters of defining a feature of the command. Following [nL][nH] is two byte hexadecimal value that denotes the length of the [00H] and [m1]...[mx] parameters. Last [m1] ... [mx] parameters are used to describe the detailed command function and represent printer settings.

The printer sends the following string in reply to the commands of this type:

```
@BDC[sp]PS[CR][LF]
XX: Reply-Data;
[FF]
```

Table 1-25 shows the XXs that are provided in this printer.

<Remote commands>

-[Save] column shows that SV commands is effective to each feature or not.
 -○: All parameters are saved., Δ: Some limited parameters are saved., -: No parameter is saved.

Table 1-25. Bi-Directional Commands

Function	Code/ Parameter	Save
Enter Remote-1	ESC"(R"08H 00H 00H "REMOTE1"	-
Exit Remote-1	ESC 00H 00H 00H	-
Save settings	"SV" 00H 00H	-
Initialize	"RS" 00H 00H	-
Load power-on default	"LD" 00H 00H	-
Select typeface	"FO" 02H 00H 00H m1 m1=0(Roman), 1(Sans serif), 5(OCR-B)*1	Δ*2
Select character pitch	"CP" 02H 00H 00H m1 m1=0(10cpi), 1(12cpi), 2(15cpi), 3 (17.1cpi), 4(20cpi), 5(Proportional)	○
Select draft or NLO	"CQ" 02H 00H 00H m1 m1=0(Draft), 1(LQ), 2(High speed draft)	○
Select character table	"CT" 02H 00H 00H m1 m1=0 (Table0), 1(Table1)	Δ*3
Assign character table	"AT" 04H 00H 00H m1 m2 m3 m1=0(Table0), 1(Table1) m2, m3=(ESC/P2 Character Table No.)*4	Δ*3
Select an international character set	"IC" 02H 00H 00H m1 m1=0(U.S.A), 1(France), 2(Germany), 3(U.K.) 4(Denmark1), 5(Sweden), 6(Italy), 7(Spain1), 8(Japan), 9(Norway), 10(Denmark2), 11(Spain2), 12(Latin America)	Δ*5
Turn 1 inch skip perforation on/off	"SK" 02H 00H 00H m1 m1=0(off), 1(on)	○

*1 Don't describe in manual.

*2 m1=0 to 1 only

*3 Only the following parameters are memorized. (Table 1-26)

Table 1-26. Note for Table 1-25

m1 set by AT/CT	m2 set by AT	m3 set by AT
0	0	0
1	All parameters that can be set	

*4 m2 and m3 apply to the following ID number. (See Table 1-27 & Table 1-28.)

Table 1-27. Std and NLSP ver.

m2	m3	Character table	m2	m3	Character table
00H	00H	Italic	19H	00H	BRASCII
01H	00H	PC437	1AH	00H	Abicomp
03H	00H	PC850	7FH	01H	ISO Latin1
07H	00H	PC860	23H	00H	Roman8
08H	00H	PC863	2CH	00H	PC858
09H	00H	PC865	1DH	0FH	ISO 8859-15
18H	00H	PC861			

Table 1-28. NLSP only

m2	m3	Character table	m2	m3	Character table
01H	10H	PC437 Greek	1CH	00H	Code MJK
05H	00H	PC853	1DH	07H	ISO 8859-7
06H	00H	PC855	1FH	00H	ISO Latin 1T
0AH	00H	PC852	20H	00H	Bulgaria
0BH	00H	PC857	21H	00H	Hebrew 7
0CH	00H	PC862	22H	00H	Hebrew 8
0DH	00H	PC864	24H	00H	PC 774
0EH	00H	PC866	25H	00H	Estonia
0EH	20H	PC866 LAT.	28H	00H	PC APTEC

Table 1-28. NLSP only

m2	m3	Character table	m2	m3	Character table
0EH	30H	PC866 UKR	29H	00H	PC 708
0FH	00H	PC869	2AH	00H	PC720
0DH	20H	PCAR_864	7FH	02H	ISO 8859-2
1BH	00H	MAZOWIA	2DH	00H	PC771

*5 m1=0 to 7 only

<Remote commands>

Table 1-29. Bi-Directional Commands

Function	Code/ Parameter	Save
Set page length	"PG" 05H 00H 00H p1 p2 m1 m2 p1=0(Continuous paper), p2=0(Rear), p1=1(CSF), p2=0(bin1) p1=2(Manual insertion), p2=0(rear) -Page length=m1+256*m2, 0.118mm (1/216inch) 648 (76.2mm(3inch)) <= m1+256*m2 <= 4752(558.8mm(22 inch))	○
Set Top margin	"TP" 05H 00H 00H p1 p1 m1 m2 p1=0(Continuous paper), p2=0(Rear), p1=1(CSF), p2=0(bin1) p1=2(Manual insertion), p2=0(rear) -Top margin=m1+256*m2, 0.118mm (1/216inch) 36 (4.2mm) <= m1+256*m2 <= 288 (8.5mm + 25.4mm(1inch))	○
Turn unidirectional mode on/off	"PD" 02H 00H 00H m1 m1=0(Bi-d.), 1(Uni-d.)	○
Turn auto tear-off on/off	"TO" 02H 00H 00H m1 m1=0(off), 1(on)	○
Turn auto line feed on/off	"LF" 02H 00H 00H m1 m1=0(off), 1(on)	○

Table 1-29. Bi-Directional Commands

Function	Code/ Parameter	Save
Select control language	"PM" 02H 00H 00H m1 m1=0(ESC/P), 2(IBM 238x Plus emulation)	○
Turn printer state reply on/off	"ST" 02H 00H 00H m1 m1=0, 1, 2, 3	-
Turn Slash zero on/off	"EX" 06H 00H 00H 00H 00H 00H 01H m1 m1=0(off), 1(on)	○
Turn Buzzer on/off	"EX" 06H 00H 00H 00H 00H 00H 02H m1 m1=0(enable), 1(disable)	○
Turn IBM emulation Auto CR on/off	"EX" 06H 00H 00H 00H 00H 00H 04H m1 m1=0(off), 1(on)	○
Set starting data/month/year	"SD" 04H 00H 00H m1 m2 m3 00<=m1<=99, 01<=m2<=12, 01<=m3<=31	○
Inquire printer state reply on/off	"ST" 01H 00H 01H "@BDC" SP "PS" CR LF "ST:" <nn> ";" FF	-
Echo parameters	"???" nL nH 01H <chr-str> "@BDC" SP "PS" CR LF "??:" <chr-str> ";" FF	-
Inquire starting date/month/year	"SD" 01H 00H 01H "@BDC" SP "PS" CR LF "SD:" <nn1> <nn2> <nn3> ";" FF	-
Inquire total printing lines/power on hours	"TL" 01H 00H 01H "@BDC" SP "PS" CR LF "TL:" ";" "TPL:" <nnnnnnnn2> ";" "TPH:" <nnnnn3> ";" "TPR:" <nnnnnnnn4> ";" FF	-

1.5.3.1 Reply Printer Status

The printer sends back one of the five strings shown below according to the printer status at that time every few seconds.

```
"@BDC"SP "ST" CR LF
"ST:" <status code>;"
["ER:" <error code>;"]
["PP:" <paper_path>;"]
["CD:" <printer status codes>;"]
["IG:" <nn1><nn2><n3>[","...<nnx1><nnx2><nnx3>"];;"]
["TEC:" <ii1>;"]
FF
```

status_code

Table 1-30. Status_Code

Status	"<status code>"
In the error state	"00"
In the busy state	"02"
In the waiting state	"03"
In the idle state	"04"
In the pose state	"05"

error_code

Table 1-31. Error_Code

Error	"<error code>"
Fatal error	"00"
Port is not selected	"01"
Release lever position error	"03"
Paper out	"06"

Paper_path

Table 1-32. Paper_Path

paper_path	"<paper_path code>"
Continuous paper (rear)	"0000"
Continuous paper (bottom)	"0001"
Cut sheet (rear)	"0200"
CSF Single bin	"0100"

 characteristic status code

Table 1-33. Characteristic Status Code

	location	size	type	Refer to
Structure version	+0	2bytes	"02" fixed	-
Starting date	+2	6bytes	"yy", "mm", "dd"	"SD" command
Total printing line number	+8	8bytes	"nnnnnnnn"	"TL" command
Total power on hour	+16	4bytes	"nnnn"	"TL" command
Total printing number for ribbon charge timing	+20	8bytes	"nnnnnnnn"	"TL" command

 MIB proxy information

"1G:"

"0305NA," Sheet feeder bin 1 (removable), capacity 5mm, quantity of paper N.A.

"09NANA," Manual feed rear, capacity N.A., quantity of paper N.A.

"0CNANA;" Tractor rear, capacity N.A., quantity of paper N.A.

"TEC:06;" 9pin SIDM

1.5.3.2 Packet commands

Table 1-34. Packet Commands

Function	Code
Device ID request	"di" 01H 00H 01H
Device ID reply (*1)	"@EJL" SP "ID" CR LF <Device ID string> FF
State-Reply request	"st" 01H 00H 01H
State-Reply (*2)	"@BDC" SP "ST" CR LF <printer status string> FF
No support command	"XX:;" FF (XX is the command string being invalid.)

NOTE: (*1) The reply string is as same as BDC-ID Reply.

NOTE: (*2) The reply string is as same as BDC-ST Reply.

1.6 Initialization

- Power-on initialization
The initialization of this level is activated by power-on or cold-reset command (remote RS command).
This initialization is;
 - to initialize the printer mechanism.
 - to execute Operator initialization.
- Operator initialization
The initialization of this level is activated by -INT signal (negative pulse).
This initialization is;
 - to clear the all buffers of data.
 - to cancel the download character definition.
 - to make the printer stand-by state, if no errors occur.
 - to execute Software initialization.
- Software initialization
The initialization of this level is activated by the control code ESC@.
This initialization is;
 - to clear the unprinted data.
 - to make the printer's setting defaults.

1.7 Paper Specifications

- Cut sheet (single sheet, not multi part)

Table 1-35. Cut Sheet (single sheet, not multi part)

	Manual insertion		CSF single-bin	
	Minimum	Maximum	Minimum	Maximum
Width (inch) (mm)	(3.9) 100	(10.1) 257	(7.2) 182	(8.5) 216
Length (inch) (mm)	(3.9) 100	(14.3) 364	(10.1) 257	(14.0) 356
Thickness (inch) (mm)	(0.0025) 0.065	(0.0055) 0.14	(0.0028) 0.07	(0.0055) 0.14
Weight (g/m ²) (lb.)	52 (14)	90 (24)	64 (18)	90 (24)
Quality	Plain paper, Reclaimed paper Not curled, not folded, not crumpled		Plain paper, Reclaimed paper Not curled, not folded, not crumpled	

NOTE: Printing on reclaimed paper is available only under normal temperature and humidity conditions.

- Cut sheet (multi part)

Table 1-36. Cut Sheet (Multi part)

		Minimum	Maximum
Width (inch) (mm)		(3.9) 100	(10.1) (257)
Length (inch) (mm)		(3.9) 100	(14.3) (364)
Copies		1 original + 4 copies	
Total Thickness (inch) (mm)		(0.0047) 0.12	(0.015) 0.39
Weight (one sheet of multipart) (g/m ²) (lb.)		52 (14)	90 (24)
Quality	Plain paper, Reclaimed paper Not curled, not folded, not crumpled.		
Joining	Line glue at the top or one side of form.		

NOTE: Printing on reclaimed paper is available only under normal temperature and humidity conditions.

Envelope

Table 1-37. Envelope

		Minimum	Maximum
Envelop (No. 6)	Width (inch) (mm)	(6.5) 165	
	Length (inch) (mm)	(3.6) 92	
Envelop (No. 10)	Width (inch) (mm)	(9.5) 241	
	Length (inch) (mm)	(4.1) 105	
Total Thickness	(inch) (mm)	(0.0063) 0.16	(0.0205) 0.52
		The difference of thickness at the printable area is within 0.25mm (0.0098 inch).	
Weight	(g/m ²) (lb.)	45 (12)	90 (24)
Quality	BOND paper, PLAIN paper or AIR MAIL No glue at a flap Not curled, not folded, not crumpled		

NOTE: Printing on reclaimed paper is available only under normal temperature and humidity conditions.

NOTE: Set the longer side of envelope horizontally.

Continuous paper (Single sheet and Multipart)

Table 1-38. Continuous Paper (Single sheet and Multi Part)

		Rear Entry		Bottom Entry	
		Min.	Max.	Min.	Max.
Width	(inch) (mm)	(4) 101.6	(10) 254	(4) 101.6	(10) 254
Length (one page)	(inch) (mm)	(4) 101.6	(22) 558.8	(4) 101.6	(22) 558.8
Copies		1 original + 4 copies		1 original + 4 copies	
Total Thickness	(inch) (mm)	(0.0025) 0.065	(0.015) 0.39	(0.0025) 0.065	(0.015) 0.39
Weight (not multipart)	(g/m ²) (lb.)	52 (14)	82 (22)	52 (14)	82 (22)
Weight (one sheet of multipart)	(g/m ²) (lb.)	40 (12)	58 (15)	40 (12)	58 (15)
Quality	Plain paper, Reclaimed paper, Carbonless multipart paper		Plain paper, Reclaimed paper, Carbonless multipart paper		
Joining	Point glue or paper staple (both sides)		Point glue or paper staple (both sides)		

Labels

Table 1-39. Continuous Paper with Labels

	Rear Entry		Bottom Entry	
	Min.	Max.	Min.	Max.
Label size	---		See the figure below.	
Base sheet width (inch) (mm)	---	---	(4) 101.6	(10) 254
Base sheet length (inch) (one page) (mm)	---	---	(4) 101.6	(22) 558.8
Base sheet thickness (inch) (mm)	---	---	(0.0028) 0.07	(0.0035) 0.09
Total thickness (inch) (mm)	---	---	(0.0063) 0.16	(0.0075) 0.19
Label weight (g/m ²) (lb.)	---		64 (17)	
Quality	---		AVERY CONTINUOUS FORM LABELS, AVERY MINI-LINE LABELS or the same quality labels	

NOTE: Printing on labels is available only under normal temperature and humidity conditions.

NOTE: The base sheet of labels must be continuous paper.

NOTE: Continuous paper with labels should be inserted from the bottom entrance.

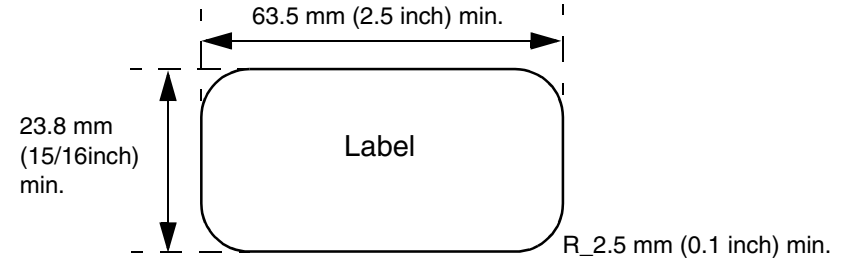

Figure 1-8. Printable Area - Label

Roll paper

Table 1-40. Roll Paper

		Minimum	Maximum
Width	(inch) (mm)	(8.5) 216	
Length	(inch) (mm)	---	
Thickness	(inch) (mm)	(0.0028) 0.07	(0.0035) 0.09
Weight	(g/m ²) (lb.)	52 (14)	82 (22)
Quality	Plain paper, Not curled, not folded, not crumpled		

1.8 Physical Specifications

□ Physical Specifications (Without pull tractor)

- Dimensions: 366 x 275 x 159 mm (WxDxH)
- Mass: Approx. 4.4 kg
- Appearance: See the figure below.

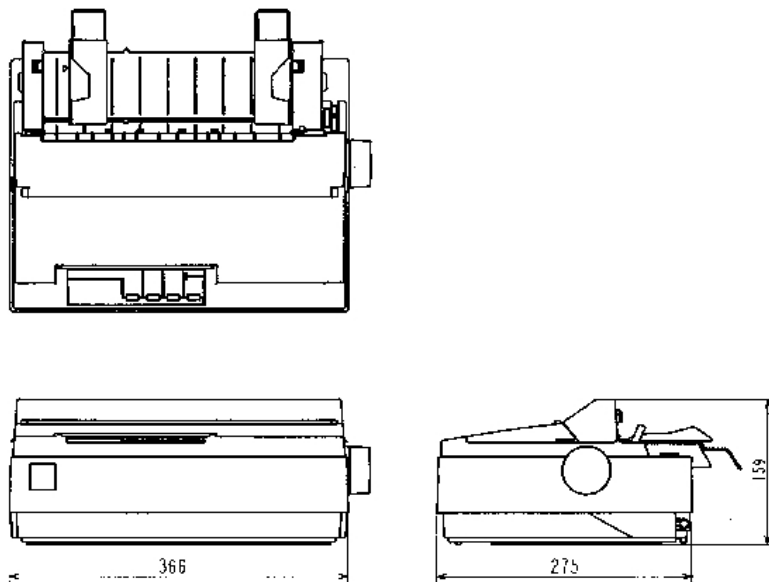

Figure 1-9. Appearance Without Pull Tractor

□ Physical Specifications (CSF)

- Dimensions: 366 x 441 x 370 mm (WxDxH)
- Mass: Approx. 4.6 kg
- Appearance: See the figure below.

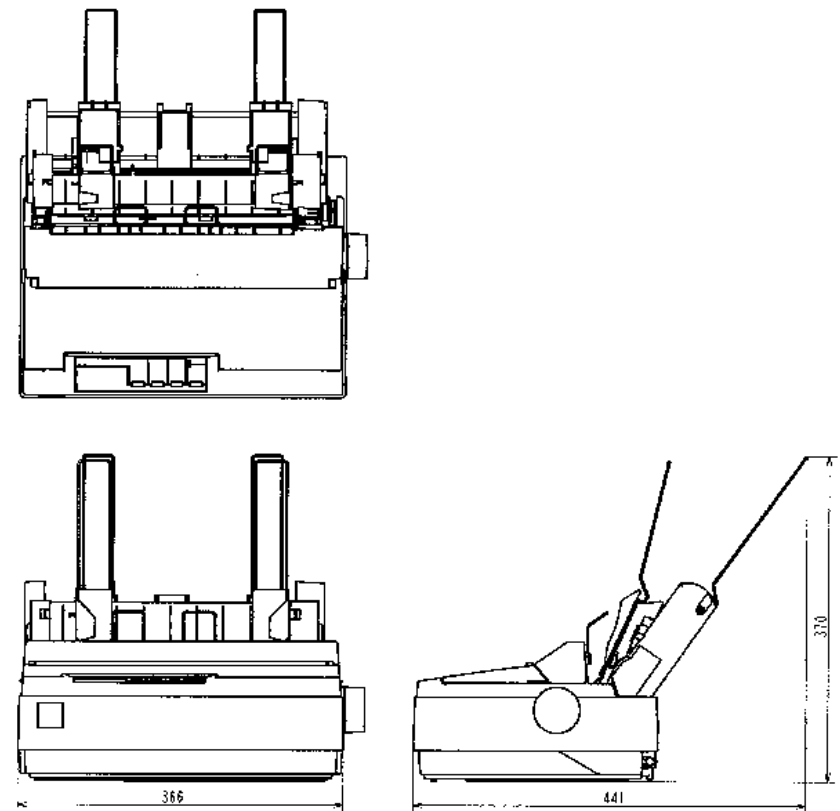

Figure 1-10. Appearance With CSF

1.9 Accessories

Table 1-41. Enclosed Parts

Enclosed Items	Quantity
User's manual	1
Driver disk	1
Ribbon cartridge (Black)	1
Power supply cable (230 V Version)	1

Table 1-42. Expendables

Enclosed Items	Description
Ribbon cartridge (Black)	#8750
Ribbon pack (Black)	#8758
Ribbon cartridge (Color)	S015073

Table 1-43. Options

Unit	Description
Cut sheet feeder	C80637*
Pull tractor unit	C80030*
Roll paper holder	#8310
Color upgrade kit	C83208*

CHAPTER

2

OPERATING PRINCIPLES

2.1 Overview

LX-300+ consists of the printer mechanism and electric circuit boards.

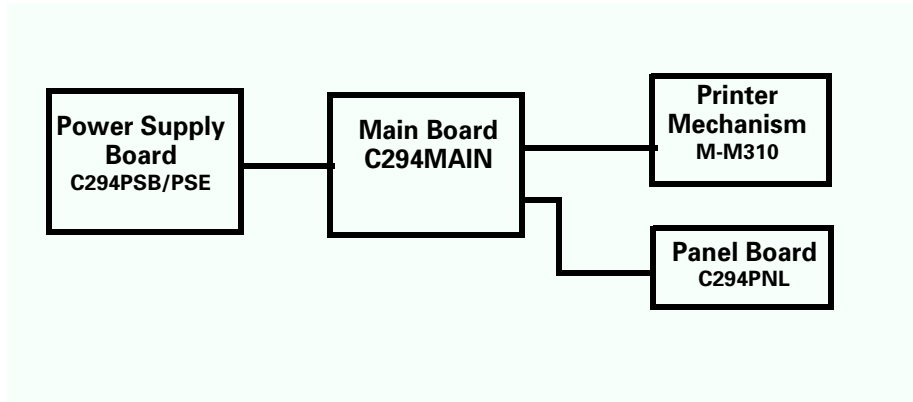

Figure 2-1. Component Unit

- Printer mechanism: M-3M10
- Circuit board
 - Main (control circuit): C294MAIN Board
 - Power: C294PSB / C294PSE Board
 - Panel: C294PNL Board

The following sections describe the operating principles of each unit.

2.2 Printer Mechanism (M-3M10)

The following is main components of the LX-300+ printer mechanism.

- Printhead
- Carriage mechanism
Carriage (CR) motor, Carriage home position (HP) detector
- Ribbon mechanism
Color ribbon drive mechanism (option)
- Platen gap adjustment mechanism
Adjust lever, Platen gap detector
- Paper feed mechanism
PF motor, rear paper end (RPE)detector, bottom paper end (BPE) detector
- Release mechanism
Release detector (REL)

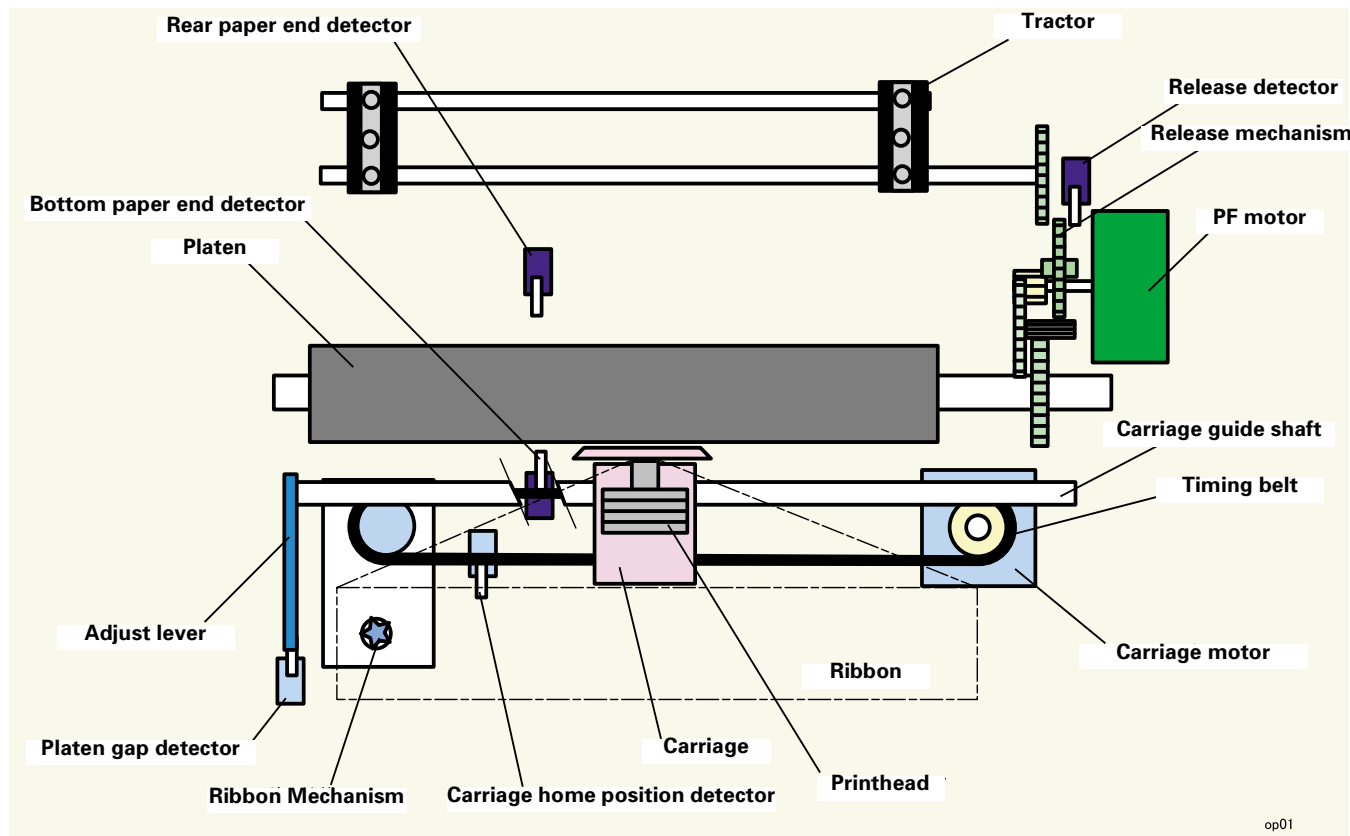

Figure 2-2. Printer Mechanism Block Diagram

2.2.1 Printhead

The table below shows the printhead specifications.

Table 2-1. Printhead Specifications

Item	Specification
Number of wires	9
Diameter of wire	φ0.29 mm
Wire configuration	See the figure below. Note: The figure is seen from the back of the head facing printing side.
Direct current coil resistance	33.3 ±3.3 Ω (25°C)
Head drive method	Rated voltage drive
Head drive voltage	35+2.1/-3.5 V
Peak current	<ul style="list-style-type: none"> • Normal: 0.75 A (Standard) • Copy: 0.85 A (Standard) 1.0 A (Maximum)
Head drive frequency	<ul style="list-style-type: none"> • Normal: 1350Hz or less • Copy: 1350Hz or less
Head life	<ul style="list-style-type: none"> • Black ribbon: 0.2 billion stroke/ wire or more • Color ribbon: 0.1 billion stroke/ wire or more
Environmental condition	<ul style="list-style-type: none"> • Temperature: 5 to 55°C • Humidity: 10 to 85%

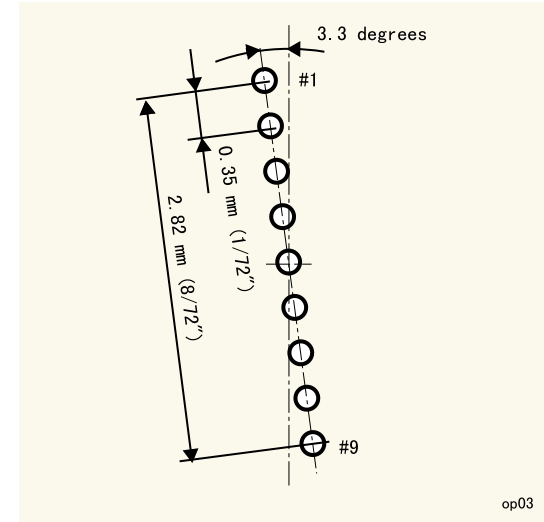

Figure 2-3. Wire Configuration

2.2.1.1 Buzzer Function

This printhead also works as a buzzer. The table below is buzzer specification.

Table 2-2. Buzzer Function -- Specification

Item	Specification
Head voltage	35 +2.1 / -3.5 V
Drive frequency	2kHz, 1.5kHz

2.2.2 Carriage Mechanism

The following is the components of the LX-300+ carriage mechanism and its explanation. (Refer to Figure 2-2, "Printer Mechanism Block Diagram")

- Carriage: Mounts the printhead.
- CR motor: Drives carriage to the printing column direction.
- Timing belt: Transfers the drive from the CR motor to the carriage.
- Carriage guide shaft: Shifts the carriage parallel to the platen.
- HP detector: Detects carriage home position.

CR MOTOR

This printer uses stepping motor for CR motor. Open loop control switches the phases according to the setting period and this mechanism enables the carriage to move until the appointed position. The table below is the CR motor specifications.

Table 2-3. CR Motor Specifications

Item	Specification
Motor type	2-phase/200-pole hybrid stepping motor
Coil resistance	5.7Ω±10% (25°C)
Control method	Bi-polar drive
Phase drive	2-2 phase, 1-2 phase, W1-2 phase
Drive voltage	36.75 ±1.75 V
CR feed pitch	Minimum Resolution: 0.212 mm (1/120") (1-2 phase, 2 pass)

The following table shows the various carriage speed modes.

Table 2-4. Carriage Speed Mode

Carriage speed mode	CR drive frequency [Hz]	Printing mode	Phase drive [pps]	Current limit (A/phase)					Adjacent dot resolution [dpi]	Head drive frequency [Hz]	Printing speed	Carriage speed mode at power down	High or low speed printing
				Front rush	High speed	Normal speed	Low speed	Rear rush					
A	3600	Color	2-2	0.79	0.79	0.70	0.70	0.70	45	1350	High speed draft 10cpi	C	○
		BW	2-2	0.70	0.59	0.59	0.59	0.59					
B	3375	Color	2-2	0.79	0.79	0.70	0.70	0.70	48	1350	High speed draft 12cpi	E	○
		BW	2-2	0.70	0.59	0.59	0.59	0.59					
C	2700	Color	2-2	0.79	0.79	0.70	0.70	0.70	60	1350	High speed draft 15cpi Draft 10cpi Bit image 60 dpi	F	○
		BW	2-2	0.70	0.59	0.59	0.59	0.59			Draft 12cpi		
D	2250	Color	2-2	0.79	0.79	0.70	0.70	0.70	1440/21	1286	High speed draft 17cpi	F	○
		BW	2-2	0.70	0.59	0.59	0.59	0.59	72	1350	Bit image 72 dpi		
E	1800	Color	2-2	0.79	0.79	0.70	0.70	0.70	80	1200	Bit image 80 dpi	G	x
		BW	1-2	0.65	0.65	0.59	0.59	0.59	90	1350	High speed draft 20cpi Draft 15cpi Bit image 90 dpi		
F	1350	Both	1-2	0.65	0.65	0.59	0.59	0.59	120	1350	Draft 20/17cpi NLQ 10cpi Bit image 120 dpi	I	x
G	1125	Both	1-2	0.65	0.65	0.59	0.59	0.59	144	1350	Bit image 144 dpi	I	x
H	900	Both	1-2	0.65	0.65	0.59	0.59	0.59	180	1350	NLQ 15cpi	I	x
I	675	Both	1-2	0.65	0.65	0.59	0.59	0.59	240	1350	NLQ 17/20cpi	J	x
J	450	Both	1-2	0.65	0.65	0.59	0.59	0.59				-	x

CARRIAGE HOME POSITION (HP) DETECTOR

The table below is the HP detector specifications.

Table 2-5. HP detector Specifications

Item	Specification
Method	Mechanical contact method
Switching rate	0.6 to 1.0 mA, 5 VD \pm 5%
Switching mode	<ul style="list-style-type: none"> out of HP: close within HP: open

HP detector detects the signal right after when the CR motor switches the phase.

2.2.2.1 High speed skip method

At no-printing area, the carriage moves at high speed compared to the normal carriage speed at printing. This is called carriage control.

2.2.3 Ribbon Mechanism

2.2.3.1 Ink Ribbon Shifting Mechanism

Ink ribbon shifting mechanism: CR motor drives timing belt and the timing belt driven pulley drives the ribbon shifting gears.

2.2.3.2 Color Ribbon Driving Mechanism (Option)

Color ribbon driving mechanism: shifts the color ribbon up and down to change the color area of the ribbon to be printed.

Color ribbon mechanism consists of the color shift (CS) motor, CS cam, ribbon detector, CS lever assembly and color cartridge holder. Color ribbon is installed on the color cartridge holder.

When CS motor revolves, 1) the pinion revolves CS cam, 2) the CS lever assembly on the CS cam shifts the color cartridge holder up and down and 3) drives ribbon up and down.

Table 2-6. CS Motor Specifications

Item	Specification
Motor type	2-phase/48-pole PM stepping motor
Coil resistance	150 Ω \pm 5% (25°C, per 1 phase)
Control method	uni-polar rated voltage drive
Phase drive	2-2 phase
Drive voltage	36.75 \pm 1.75 VDC
Consuming current	<ul style="list-style-type: none"> Operating, peak current: 245 mA Non-operating: 20 mA
Drive frequency	500 pps

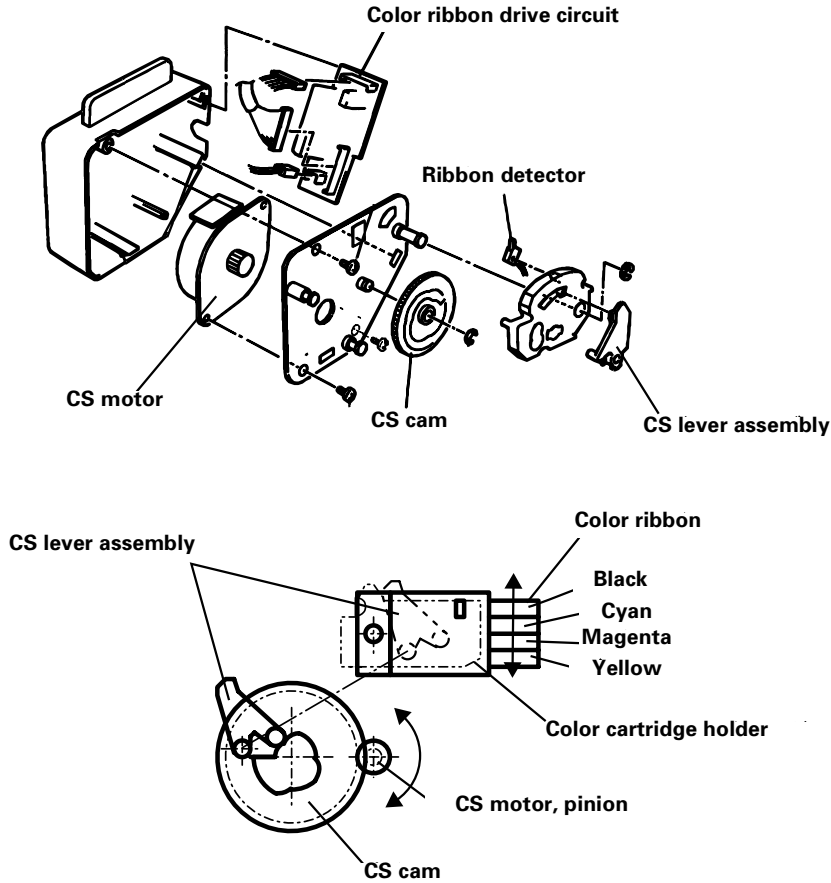

Figure 2-4. Color Ribbon Driving Mechanism

op04

RIBBON CARTRIDGE DETECTOR

Ribbon detector detects if the color ribbon is installed or not.

- Detect Timing
 - When the power is applied.
 - When recovering from the economy mode.
 - When the printing is started.

Table 2-7. Ribbon Detector Specifications

Item	Specification
Method	Mechanical contact method
Switching rate	0.6 to 1.0 mA
Switching mode	<ul style="list-style-type: none"> • Color ribbon cartridge is installed: High • Black ribbon cartridge is installed or ribbon is not installed: Low

AVOID COLOR FROM MIXING

To avoid the color area on the ribbon from mixing up each other or minimize the color mixing up, the printing is done by the following order when printing green, violet and orange.

Table 2-8. Color Printing Order

Color	First color	Second color
Green	Yellow	Cyan
Orange	Yellow	Magenta
Violet	Magenta	Cyan

COLOR MECHANISM INITIALIZATION

The printer mechanism initializes when the power is applied or when recovering from the energy saving mode.

- Color mechanism initialization
Color mechanism initialization shifts color mechanism for the black ink area to be at the home position. Color mechanism initialization shifts the carriage at the same time to prevent the ribbon from hanging on the printhead.
When the buffer is cleared or when the printer is under the pause condition, the color mechanism initializes and waits for the next printing command.

2.2.4 Platen Gap Adjustment Mechanism

This mechanism is to adjust the distance between the platen and the printhead (platen gap) according to the paper thickness.

The following is the components of the LX-300+ platen gap adjustment mechanism and its explanation. (Refer to Figure 2-5, "Platen Gap Adjustment Mechanism")

- Carriage: Mounts the printhead.
- Carriage guide shaft: Shifts the carriage horizontally.
- Adjust lever and Parallelism adjust bushing: Installed at the both ends of the carriage guide shaft
- Platen gap detector (PG_SW)

Carriage guide shaft is eccentric toward the adjust lever rotating center. Due to this, when rotating the adjustment lever back and forth, the printhead shifts toward and against the platen to adjust the platen gap. When printing on thick paper such as postcards and envelopes, set the adjust lever over the 1st level. PG detector shifts the printer to the copy mode from the printing mode. Printing speed will be lowered but it prevents wire from breaking off.

PLATEN GAP (PG_SW) DETECTOR

The following is PG_SW specification.

Table 2-9. PG_SW Detector Specifications

Item	Specification
Method	Mechanical contact method
Switching rate	0.6 to 1.0 mA, 5 VD±5%
Switching mode	<ul style="list-style-type: none"> • PG=0: close • PG=0-4: open

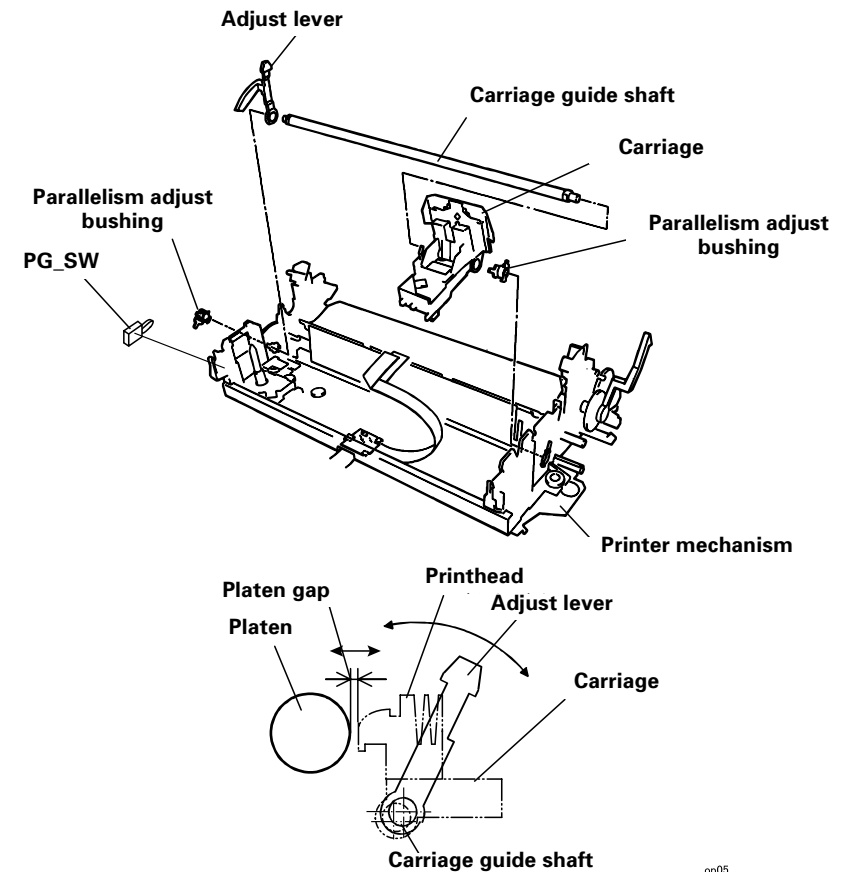

Figure 2-5. Platen Gap Adjustment Mechanism

2.2.5 Paper Feed Mechanism

This mechanism consists of paper feed motor (PF motor), paper feed gears, platen, rear paper end detector, bottom paper end detector and push tractor unit. (Refer to Figure 2-2, "Printer Mechanism Block Diagram")

- Paper Feed Method
 - Friction feed
 - Push tractor feed
Uses standard push tractor
 - Push-pull tractor feed
Uses standard push tractor + Option tractor
 - Pull tractor feed
Replace the standard push tractor with option tractor
- Feeder
 - Simple CSF (option)
 - Tractor (standard)
Push / Pull
 - Pull tractor (option)
 - Roll paper holder
- Paper path
 - Manual loading
Rear paper load, top paper load
 - CSF
Rear paper load, top paper load
 - Push tractor
Rear paper load, top paper load
 - Pull tractor
Rear / Bottom paper load, top paper load
- Auto loading
When loading paper manually, push paper between the platen and the driven paper load roller. Paper will be loaded automatically.

PF MOTOR

LX-300+ uses the stepping motor for PF motor. Open loop control switches the phase according to the

LX-300+ uses stepping motor for PF motor. Open loop control switches the phases according to the setting period and this mechanism loads and carries paper to the appointed position and eject paper.

The table below is the PF motor specifications.

Table 2-10. PF Motor Specifications

Item	Specification
Motor type	2-phase/96-pole Hybrid stepping motor
Coil resistance	16.0Ω ±10% (25°C, per 1 phase)
Control method	bi-polar rated current drive
Phase drive	1-2 phase, W1-2 phase
Drive voltage	36.75 ± 1.75 VDC (This voltage is added to driver.)
Drive current	0.1 to 0.9A
Paper feed pitch	Minimum Resolution: 0.059 mm (1/432") (1-2 phase, 2 pass)

RPE DETECTOR

RPE detector is installed on the paper path at the back of the printer. The table below shows the RPE detector specifications.

Table 2-11. RPE Detector Specifications

Item	Specification
Method	Mechanical contact method
Switching rate	0.6 to 1.0 mA, 5 VD±5%
Switching mode	<ul style="list-style-type: none"> • Paper inside: open • No paper: close

BPE DETECTOR

BPE detector is installed right under the platen. The table below shows the BPE detector specifications.

Table 2-12. BPE Detector Specifications

Item	Specification
Method	Mechanical contact method
Switching rate	0.6 to 1.0 mA, 5 VD±5%
Switching mode	<ul style="list-style-type: none"> • Paper inside: open • No paper: close

2.2.5.1 Page Length Measurement

Page length measurement is a process to convert the following value to the number of printing lines.

Value = [The number of paper feed pulse from the paper top (top margin: 4.2mm) until RPE detector detects paper end] + [forms over-ride specified paper feed pulse] - [adjustment value]

- When CSF is used:
The uncertainty of the paper end detector may vary the number of printing lines within the same paper size. To avoid this, when CSF is used, page length measurement calculates the printable lines and if the paper is longer than the printable lines, the number of printing line is considered the printable lines (fixed value).
When paper is shorter than the printable lines, the printer prints the fixed number of lines by forms over-ride function (which allows the fixed number of lines to be printed even when RPE detector detects paper end).
- When CSF is not used:
When loading paper manually or when tractor feed is used, the number of printing lines of paper end is determined by forms over-ride function after BPE or RPE detector detects paper end.

2.2.6 Release Mechanism

This mechanism switches the flow of PF motor driving forth between to the friction feed and to the tractor feed.

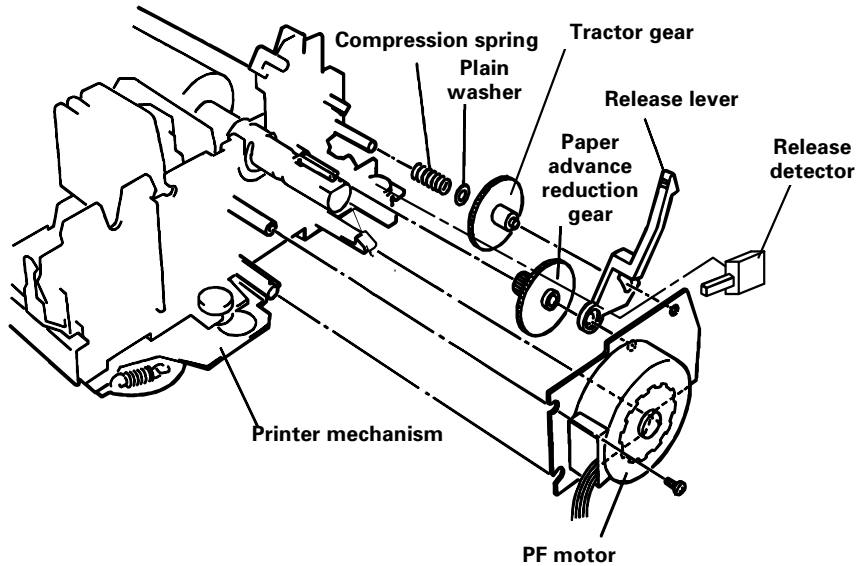

op06

Figure 2-6. Release Mechanism

Release mechanism consists of the following.

- Release lever: Shifts tractor low speed gears back and forth.
- Tractor gear
- Paper advance reduction gear: Transfers the PF motor driving forth to the tractor gear.
- Release detector (REL): Detects the release lever position.

The table below shows the release detector specifications.

Table 2-13. Release Detector Specifications

Item	Specification
Method	Mechanical contact method
Switching rate	0.6 to 1.0 mA, 5 VD±5%
Switching mode	<ul style="list-style-type: none"> • Friction: open • Tractor: close

2.2.7 Other Special Functions

2.2.7.1 Energy saving mode

This function saves electric consumption when the printer is in the standby mode. This mode turns hold current of PF motor, CR motor and CS motor OFF.

2.2.7.2 Quiet Mode

Quiet mode lowers printing temperature. When this mode is selected, carriage speed will be lowered to the power down mode speed. Refer to Table 2-4, "Carriage Speed Mode," on page 46.

2.3 Electric Circuit Operating Principles

2.3.1 MAIN Board (Control Board) Electric Circuit

The figure below is the MAIN board block diagram.

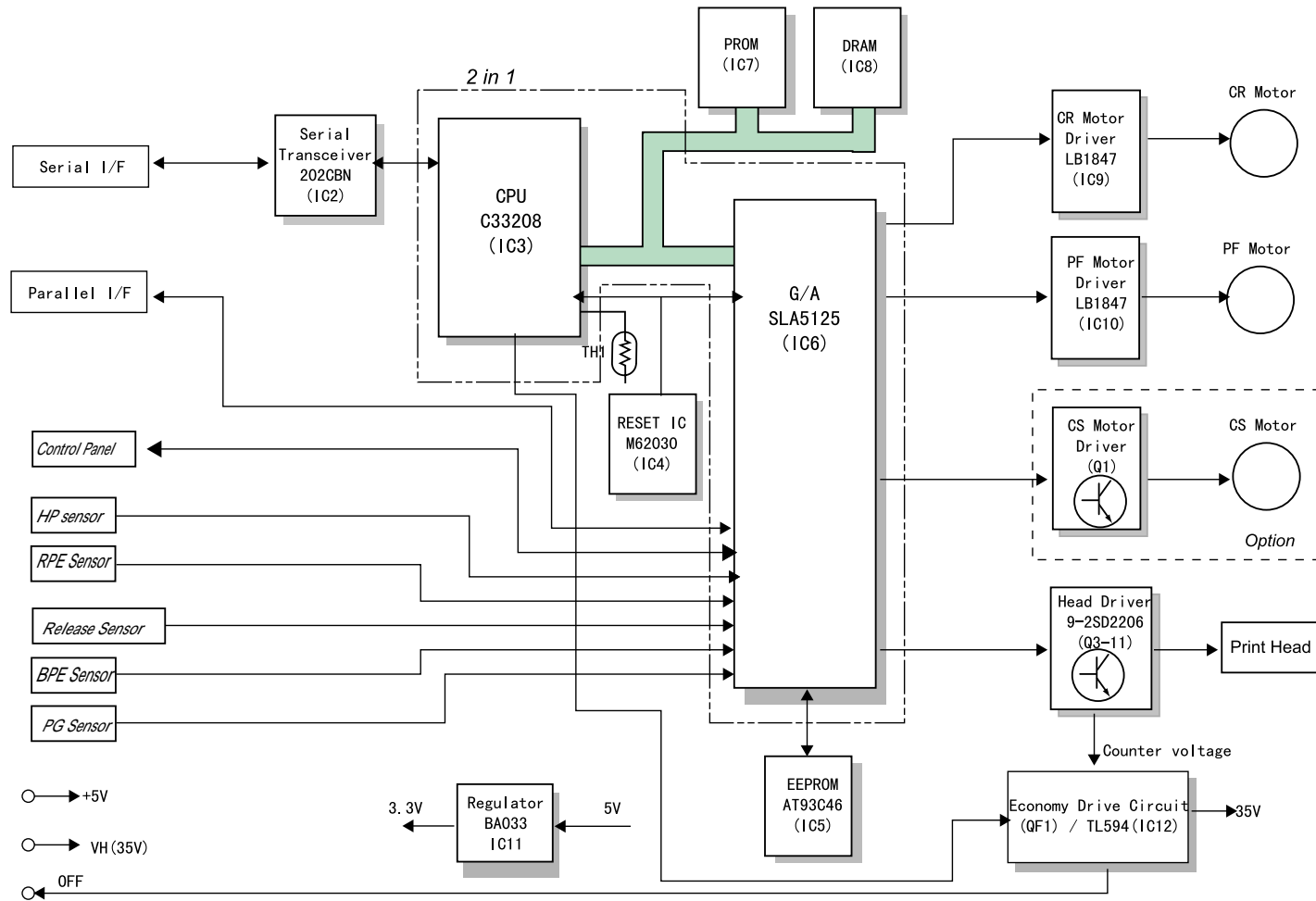

op07

Figure 2-7. MAIN Board Block Diagram

Table 2-14. Main Elements

Elements	Location	Function
CPU	IC3	RISC C33208 CPU, QFP 128 pin <ul style="list-style-type: none"> • Outside clock 19.66 MHz/ Inside clock 39.32 MHz • 8KBRAM built-in • Various DMA • A/D converter
G/A *	IC6	Approximately 21000 gates, QFP 160 pin <ul style="list-style-type: none"> • Bit manipulation • Clock control • interface control (IEEE1284/Type-B I/F) • Input Buffer control • Motor control • Head control
PROM	IC7	4M / 8Mbit, DIP 40 / 42 pin <ul style="list-style-type: none"> • Stores firmware • CG
DRAM	IC8	1/2/4M bit switching method, SPJ package 40 pin <ul style="list-style-type: none"> • Various buffer, work area
EEPROM	IC5	AT93C46, 1kbit, SOP 8pin <ul style="list-style-type: none"> • Stores default value and various parameter
RESET IC	IC4	M62030 (SANYO), 8 pin <ul style="list-style-type: none"> • CPU and G/A reset
CR Motor Driver	IC9	LB1847 (SANYO)
PF Motor Driver	IC10	LB1847 (SANYO)
Serial I/F Transceiver	IC2	HIN202CBN or equivalent
Regulator IC	IC11	BA033 (ROHM) or equivalent <ul style="list-style-type: none"> • Generates 3.3V logic voltage
Regulator IC	IC12	PD494 or equivalent <ul style="list-style-type: none"> • 95V rated voltage circuit • Detects over voltage (over 150V) and sends OFF signal to the power supply boards.
Thermistor	TH1	Measures temperature of the motor driver.

NOTE: *: CPU and G/A will be changed to 2in1 type later.

2.3.2 C294PSB / C294PSE Board

LX-300+ generates power supply by 2 power supply boards: C294PSB (100V) and C294PSE (200V). The table below shows the power supply boards input voltage specifications.

Table 2-15. Power Supply Boards Input Voltage Specifications

Circuit	Input voltage	Fuse specification
C294PSB	99 - 132VAC	ULTSC-2.5A-NI
C294PSE	198 - 264VAC	HT 1.25A

2.3.2.1 Electric Circuit

The power supply board supplies two types of power for control circuit and driving mechanism. The table below shows output voltage and its use.

Table 2-16. Output Voltage and its Use

Output voltage	Use
35 V +5%/ -10%	Drive
5 V ± 5%	Logic Voltage*

NOTE: *: Core voltage of CPU and G/A is 3.3V and it is generated by the regulator IC on the MAIN board form +5VDC.

CHAPTER

3

TROUBLESHOOTING

3.1 Overview

This chapter describes how to troubleshoot problems when any problems occurred to the printer.



- Never touch printhead and any motors right after printing since they are highly heated.
- When disassembling the printer, be sure to disconnect the power cable and remove the interface cable.



- Be sure to use specified tools for servicing to maintain the quality.
- Make sure to apply specified oil, grease and glue.
- Perform adjustment as specified.

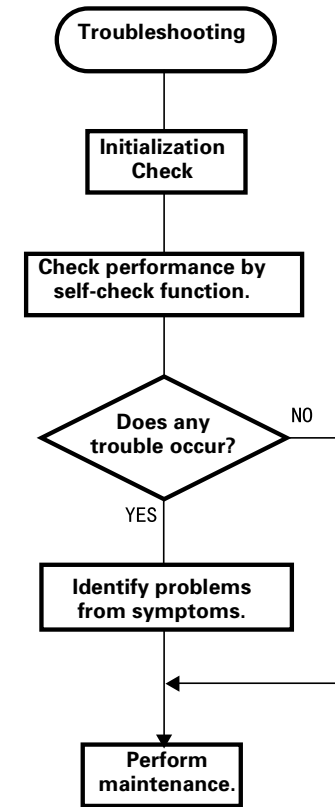

Figure3-1. Troubleshooting Procedure

3.2 Troubleshooting

3.2.1 Initialization Check

Before troubleshooting, check the following basic items.

1. When printer can perform printing, perform self-test and check if any troubles occur.
2. When the printer cannot perform any printing, check the setting by "Default Setting". (Refer to Chapter 1.)
3. Check if the outside and inside the printer is noticeably dirty or if any parts are broken. If there is dirt, perform cleaning referring to Chapter 6 "Maintenance".
4. Make sure each harness is connected properly.
5. Make sure no remarkable friction among printer mechanism gears. Make sure all gears are linked properly.
6. Make sure there is no dirt nor scratch on rollers inside the printer.
7. Perform EEPROM clear as needed. Inside setting is reset to the factory default setting. (Refer to Chapter 1.)

3.2.2 Check Performance By Self-Check Function

LX-300+ has self-check function and it supervises the printer condition constantly. If any problem occurs, it indicates error by indicator LED and in some cases it notifies error to the operator by beeping the buzzer. Identify error cause, referring to the indication first. If error is not solved, perform unit repair.

3.2.2.1 Indicator LED

The table below shows the indicator LED and the printer condition.

Table 3-1. Indicator LED

Printer Condition	Pause	Paper Out	Front	Buzzer
Pause	ON	-	-	-
Paper Out Error	ON	ON	-	Shoot beep x3
Release Lever Error	ON	-	-	Long beep x5
Paper Eject Warning	ON	BLINK	-	-
MICRO Adjust	BLINK	-	-	-
Tear Off	-	-	According to LED On/Off combination	-
Font Select	-	-	According to LED On/Off combination	-
Fatal Error	BLINK	BLINK	BLINK	-

- Paper Out Error
 - This error will be indicated when printer fails to feed paper or paper is run out.
 - Solution
 - Set paper properly and try paper feed again.

- Release Lever Error
This error will be indicated when wrong release lever operation is performed. For example, if you change the release lever setting when the printer already starts feeding paper, this error will be generated.
 - Solution
Reset the release lever.
- Fatal Error
This error will be indicated when;
 - carriage error is occurred
 - input voltage is abnormal
 - hardware problem is occurred
 - Solution
If it is carriage error, check if there is no obstacles for carriage to move.
If it is input voltage problem, check power supply voltage.
If it is hardware problem, check machine and electric circuit.

3.2.3 Identify Problems From Symptoms

This section procedure to identify the problems from the abnormal symptoms. Basically unit repair or replacement should be performed, but if necessary parts level replacement should be performed.

Find your symptom in the table below and check the corresponding table.

Table 3-2. Symptoms and Solutions

Symptom	Problems	Check Table
When power is applied, the printer does not operate.	Control panel LED does not operate at all.	Table 3-3 on page 59
	Printer mechanism does not operate at all.	Table 3-4 on page 59
When power is applied, the printer becomes fatal error.	<ul style="list-style-type: none"> • Control panel indicates fatal error. • The printer indicates error after initialization. 	Table 3-5 on page 59
Self-test print is abnormal.	<ul style="list-style-type: none"> • Platen gap is not correct. • Printhead and ribbon mask is abnormal or their life are over. • Vertical direction printing quality is abnormal. 	Table 3-6 on page 60
Paper feed is abnormal.	<ul style="list-style-type: none"> • Paper feed operation is not performed. • Paper switching is abnormal. • Line feed is not equal. • Skew is generated. 	Table 3-7 on page 60
Control panel and switches do not operate properly.	<ul style="list-style-type: none"> • LED indication is abnormal. • Cannot input from switches. 	Table 3-8 on page 60
Printing operation is abnormal when it is on-line.	<ul style="list-style-type: none"> • Self-test is normal, but the printing from host computer is abnormal. 	Table 3-9 on page 61

Table 3-3. Control Panel LED Does Not Light On.

Cause	Check Point	Y/N	Solution
Blowout of a fuse on the power board.	Is a fuse on the power board blew out?	YES	Check the electric circuit and printer mechanism. If there is no short circuit, replace the fuse.
Connector is not connected to the power board.	Are connectors connected to the power board properly?	NO	Replace the power board.
Power switch is defective.	Is conductivity of the switch is OK?	YES	Replace the power board.
Power board is defective.	Are +5VDC and +35VDC OK when the power is on?	NO	Replace the power board.
Power board and the main board are not connected properly.	Is CN8 connected properly?	NO	Connect CN8 properly.
Main board is defective.	-	-	Replace the main board.
Control panel harness is not connected properly.	Is the harness of the control panel connected properly?	NO	Connect the harness properly.
Control panel board or harness is defective.	-	-	Replace the control panel.

Table 3-4. Printer Mechanism Does Not Operate.

Cause	Check Point	Y/N	Solution
Any of CN3 to CN12 is not connected to the main board properly.	Are all connectors connected properly?	NO	Connect them properly.
Main board is defective.	-	-	Replace the main board.
Printer mechanism is defective.	-	-	Replace the printer mechanism.

Table 3-5. When Power is Applied, the Printer Becomes Fatal Error.

Cause	Check Point	Y/N	Solution
CR motor harness is not connected properly.	Is CR motor harness CN10 connected properly?	NO	Connect it properly.
CR motor is defective.	-	-	Replace the CR motor.
HP detector harness is not connected properly	Is HP detector harness CN3 connected properly?	NO	Connect it properly.
HP detector is defective.	-	-	Replace the HP detector.
Power board is defective.	Is power voltage normal?	NO	Replace the power board.
-	-	-	Replace the main board and printer mechanism.

Table 3-6. Self Test Print is Abnormal.

Cause	Check Point	Y/N	Solution
Any of CN3 to CN12 is not connected to the main board properly.	Are all connectors connected properly?	NO	Connect them properly.
Printhead driver is defective.	-	-	Replace the main board.
Bi-d is not correct.	Are rows aligned properly when bi-directional printing is proceeded?	NO	Adjust Bi-D.
Printhead is defective.	Is there any dot missing?	YES	Replace the printhead.
Head FFC is not connected properly or broken.	-	YES	Replace the head FFC.
Platen gap is not correct.	Is printing too light / weak?	YES	Adjust the platen gap.
	Is there any dirt on printed documents?	YES	Adjust the platen gap.
Ribbon mask is defective.	Is there any dirt on printed documents?	YES	Replace the ribbon mask.
Ribbon mechanism is defective.	Is ribbon advanced properly?	NO	Replace the ribbon mechanism parts.
Printer mechanism is defective.	-	-	Replace the printer mechanism.

Table 3-7. Paper Feed is Abnormal.

Cause	Check Point	Y/N	Solution
RPE detector or BPE detector is defective or not connected properly.	Check the sensors. Is there any abnormality?	NO	Replace the sensor.
		YES	Check the connection to the main board.
Paper switching mechanism is defective.	Switch the release lever. Is the paper loading direction switched?	NO	Replace the printer mechanism or check the connection.
	Can the release lever be switched?	NO	Replace the release sensor or check the connection.
Printer mechanism paper loading mechanism is defective.	When the power is off, can the printer feed paper by rotating the platen knob manually?	NO	Replace the printer mechanism or paper loading mechanism parts.
PF motor is defective.	Is PF motor normal?	NO	Replace the PF motor.
PF motor driver is defective.	-	-	Replace the main board.

Table 3-8. Control Panel and Switches Do Not Operate.

Cause	Check Point	Y/N	Solution
Switch is defective.	Is conductivity of the switch is OK?	NO	Replace the control panel.
Connect the control panel harness.	Control panel harness is connected properly?	NO	Connect it properly.
Control panel board is defective or the harness is defective.	-	-	Replace the control panel.

**Table 3-9. Printing Operation is Abnormal When it is On-Line.
(Self-Test is Normal.)**

Cause	Check Point	Y/N	Solution
Initial setting is wrong.	Check the initial setting with the default setting. Is it OK?	NO	Reset the setting or use the EEPROM clear to reset setting to the default.
Interface cable is not connected properly.	Are cables connected properly?	NO	Connect them properly.
Interface cable is defective.	-	-	Replace the interface cable.
Main board is defective.	-	-	Replace the main board.
Firmware is defective.	Is the firmware version latest?	NO	Replace the firmware.

3.2.4 Unit and Parts Check

This section describes the checking method of the printhead, motors and sensors to find the defective units and parts.



When repairing the unit, make sure to turn the printer off and plug off the power cable except when this manual specifies to keep the power on.

3.2.4.1 Printhead Check

By measuring the direct current resistance of the printhead coil, you can check if it is all right.

Table 3-10. Printhead Coil Resistance

Item	Operation	Specification
Printhead	1. Set the multimeter to the resistance measuring range. 2. Connect the one side of the probe to C. 3. Connect the other side of the probe to corresponding head pin No.	$33.3 \pm 3.3\Omega$ (at 25°C/phase)

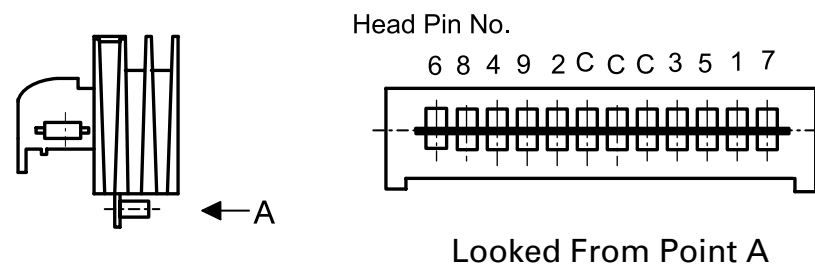

trb01

Figure3-2. Head Coil Pin No.

3.2.4.2 Motor Check

By measuring the direct current resistance of the motor coil, you can check if the motor is all right.

Table 3-11. Motor Check

Item	Operation	Specification
CR motor	<ol style="list-style-type: none"> 1. Set the multimeter to the resistance measuring range. 2. Connect the one side of the probe to 1 or 2 pin. 3. Connect the other side of the probe to 3 or 4 pin. 	5.7Ω ±10% (at 25°C/phase)
PF motor	<ol style="list-style-type: none"> 1. Set the multimeter to the resistance measuring range. 2. Connect the one side of the probe to 1 or 2 pin. 3. Connect the other side of the probe to 3 or 4 pin. 	16.0Ω ±10% (at 25°C/phase)
CS motor (option)	<ol style="list-style-type: none"> 1. Disassemble the CS unit. 2. Set the multimeter to the resistance measuring range. 3. Connect the one side of the probe to brown [TBD] harness. 4. Connect the other side of the probe to other 4 harness. 	150Ω ± 5% (at 25°C/phase)

3.2.4.3 Sensor Check

When the sensor is connected mechanically, you can check the sensor by its conductivity.

Table 3-12. Sensor Check

Item	Operation	Specification
HP detector	<ol style="list-style-type: none"> 1. Set the multimeter to the resistance measuring range. 2. Connect the one side of the probe to CN3 1 pin. 3. Connect the other side of the probe to CN3 2 pin. 	When switching the sensor actuator, it should be switched ON/OFF.
RPE detector	<ol style="list-style-type: none"> 1. Set the multimeter to the resistance measuring range. 2. Connect the one side of the probe to CN4 1 pin. 3. Connect the other side of the probe to CN4 2 pin. 	When switching the sensor actuator, it should be switched ON/OFF.
Release detector	<ol style="list-style-type: none"> 1. Set the multimeter to the resistance measuring range. 2. Connect the one side of the probe to CN5 1 pin. 3. Connect the other side of the probe to CN5 2 pin. 	When switching the sensor actuator, it should be switched ON/OFF.
BPE detector	<ol style="list-style-type: none"> 1. Set the multimeter to the resistance measuring range. 2. Connect the one side of the probe to CN6 1 pin. 3. Connect the other side of the probe to CN6 2 pin. 	When switching the sensor actuator, it should be switched ON/OFF.
PG detector	<ol style="list-style-type: none"> 1. Set the multimeter to the resistance measuring range. 2. Connect the one side of the probe to CN3 7 pin. 3. Connect the other side of the probe to CN3 7 pin. 	When switching the sensor actuator, it should be switched ON/OFF.

3.2.4.4 Printhead Driver Check

Simple check of the printer driver (Q3 ~ Q11) can be done by the following method.

Table 3-13. Printhead Driver Check

Item	Operation	Specification
Printer driver (Q3 ~ Q11)	<ol style="list-style-type: none">1. Set the multimeter to the resistance measuring range.2. Connect the one side of the probe to the base of the transistor.3. Connect the one side of the probe to emitter of the transistor.	The resistance should NOT be "0" or infinity.

CHAPTER

4

DISASSEMBLY AND ASSEMBLY

4.1 Overview

This chapter explains the disassembly and assembly of LX-300+.

4.1.1 Precautions

Read the precautions below before disassembling and assembling the printer.



- When disassembling and adjusting the printer, remove the AC cable off the socket.
- Never touch the printer right after it finishes printing, for the printhead is highly heated.



- For disassembly and assembly of the printer, use the tools specified in this chapter.
- Use the specified oil and grease.
- When performing the adjustment, follow the method described in this manual.

4.1.2 Tools

The table below lists the tools recommended to use for disassembly and assembly and adjustment. Use only tools specified here.

Table 4-1. Recommended Tools

Tools	Part No.
Needle-nose pliers	B740400100
Nipper	B740500100
Tweezers	B741000100
Soldering bit	B740200100
E ring holder #2.5	B740800400
+ driver No.2	B743800200
Box driver (opposite side distance: 7mm)	B741700200
Thickness gauge	B776702201

NOTE: All tools are available in market.

Table 4-2.

Device	Specification
Multimeter	-
Oscilloscope	50MHz

NOTE: Only component level repairing service requires oscilloscope.

4.1.3 Service Checks After Repair

Before returning the printer back to the user, use the check list below to confirm the quality of the repaired printer.

Table 4-3. Check List for Repaired Printer

Category	Component	Item to Check	Check
Printer Mechanism	Printhead	Is dot missing?	<input type="checkbox"/> OK <input type="checkbox"/> NG
		Are any wires broken?	<input type="checkbox"/> OK <input type="checkbox"/> NG
	Carriage mechanism	Does carriage move smoothly? <input type="checkbox"/> CR movement is not noisy? <input type="checkbox"/> CR mechanism is not dirty? <input type="checkbox"/> CR mechanism is not oily?	<input type="checkbox"/> OK <input type="checkbox"/> NG
		Is the CR motor assembly at the correct temperature? (Not overheating?)	<input type="checkbox"/> OK <input type="checkbox"/> NG
	Paper feed mechanism	Is paper advancing smoothly? <input type="checkbox"/> PF movement is not noisy? <input type="checkbox"/> PF mechanism is not dirty? <input type="checkbox"/> PF mechanism is not oily?	<input type="checkbox"/> OK <input type="checkbox"/> NG
		Is the PF motor assembly at the correct temperature? (Not overheating?)	<input type="checkbox"/> OK <input type="checkbox"/> NG
	Paper path	Are all the types of paper fed smoothly?	<input type="checkbox"/> OK <input type="checkbox"/> NG
		Does the tractor feed paper smoothly?	<input type="checkbox"/> OK <input type="checkbox"/> NG
		Is the paper path clear of obstructions?	<input type="checkbox"/> OK <input type="checkbox"/> NG
		Is the platen free of damage?	<input type="checkbox"/> OK <input type="checkbox"/> NG
	Ribbon mask	Is the ribbon mask free of distortion?	<input type="checkbox"/> OK <input type="checkbox"/> NG
	Test printing	Is the test printing successful?	<input type="checkbox"/> OK <input type="checkbox"/> NG
	Online printing	Is the online printing successful?	<input type="checkbox"/> OK <input type="checkbox"/> NG

Table 4-3. Check List for Repaired Printer

Category	Component	Item to Check	Check
Adjustment	Printhead	Is the platen gap adjusted correctly?	<input type="checkbox"/> OK <input type="checkbox"/> NG
		Is Bi-d adjustment value correct?	<input type="checkbox"/> OK <input type="checkbox"/> NG
	Initial setting	Have all user changeable settings been reset to the default value?	<input type="checkbox"/> OK <input type="checkbox"/> NG
Version Up	ROM version	Latest ROM version _____	<input type="checkbox"/> OK <input type="checkbox"/> NG
Transportation	Ink ribbon	Is ribbon removed?	<input type="checkbox"/> OK <input type="checkbox"/> NG
	accessories	Are all the relevant parts included in the shipment?	<input type="checkbox"/> OK <input type="checkbox"/> NG

4.2 Disassembly and Assembly

This section explains the disassembly and assembly of LX-300+. Unless otherwise specified, assembly can be done in the reverse order of the disassembly procedure.

Anything that service person should pay attention to is described under "Check Point". Any adjustment required after assembly is described under "Adjustment".

When you have to remove parts that are not described in this chapter, refer to the exploded diagram on Appendix of this manual.

- CAUTION**
- Read 4.1.1 "Precautions" before start disassembling the printer.
 - Remove ink ribbon and paper before disassembling the printer.

The figure below is the disassembly flowchart for main component.

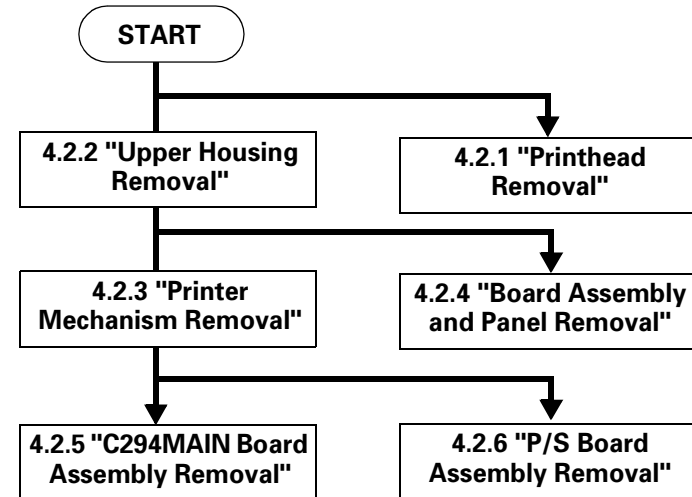

Flowchart 4-1. Disassembly Flowchart (Main Component)

4.2.1 Printhead Removal

1. Remove the cover and the printer.
2. Remove 1 screw (CPB, 3x14) securing the printhead to the carriage assembly.
3. Lift the printhead a little bit. Unlatch 2 hooks securing the printhead FFC to carriage unit.
4. Remove FFC from the printhead.



CAUTION Check if the printer is powered off before removing the printhead.



ADJUSTMENT REQUIRED When the printhead is replaced, perform the platen gap adjustment.

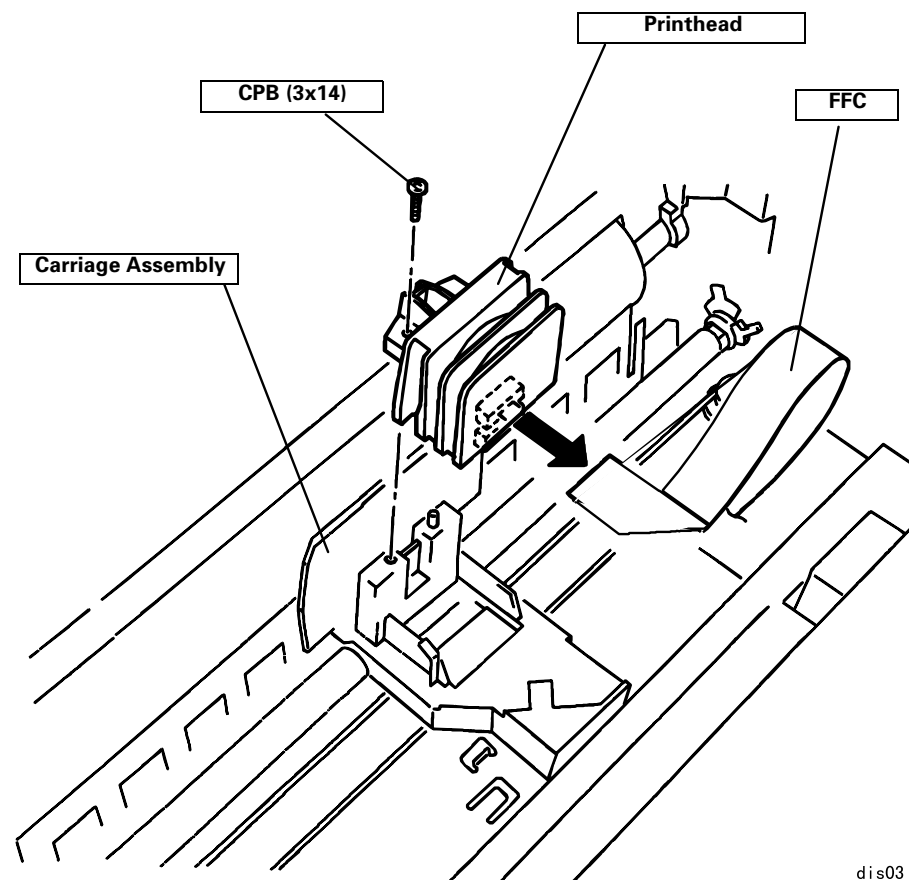

dis03

Figure4-1. Printhead Removal

4.2.2 Upper Housing Removal

1. Remove platen knob, cover assembly, printer, tractor unit and paper eject unit. Remove the color upgrade kit if it is installed.
2. Set the release lever to the tractor feed.
3. Remove 4 screws (CBP, 3x10) securing the upper housing to the lower housing.
4. Remove the upper housing.



When installing the upper housing, be sure to insert LEDs on the panel board to the LED holes of the upper housing.

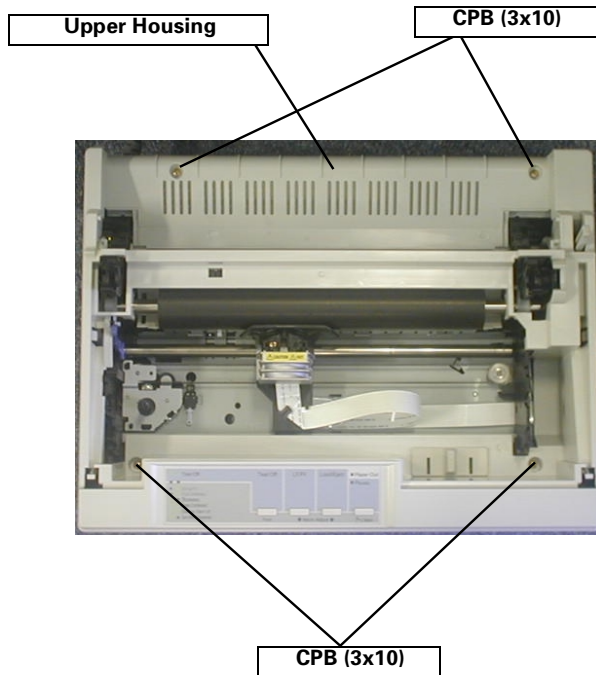

dis05

Figure4-2. Upper Housing Removal

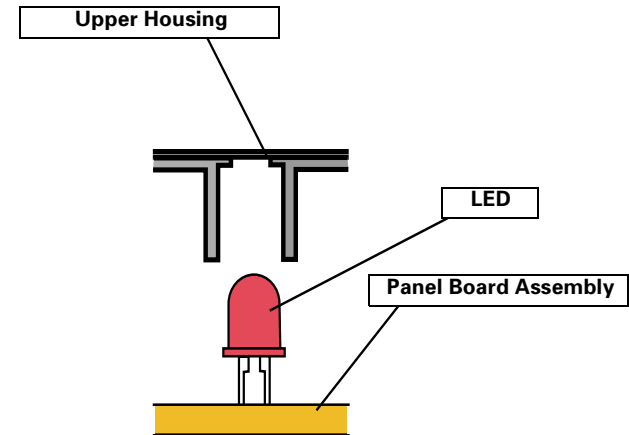

dis04

4.2.3 Printer Mechanism Removal

1. Remove the upper housing. (See 4.2.2 "Upper Housing Removal".)
2. Remove 3 screws (CBP, 3x10) securing the upper shield plate to the lower housing. Remove the shield cover.

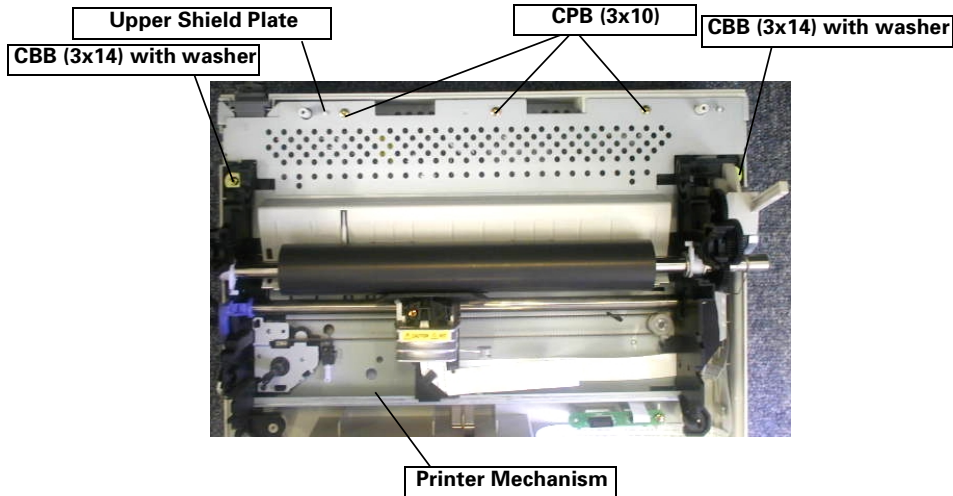

Figure4-3. Upper Shield Plate

3. Remove 2 screws with washer (CBP, 3x14) securing the printer mechanism to the lower housing.
4. Lift the printer mechanism a little bit and remove harnesses from the main board assembly.

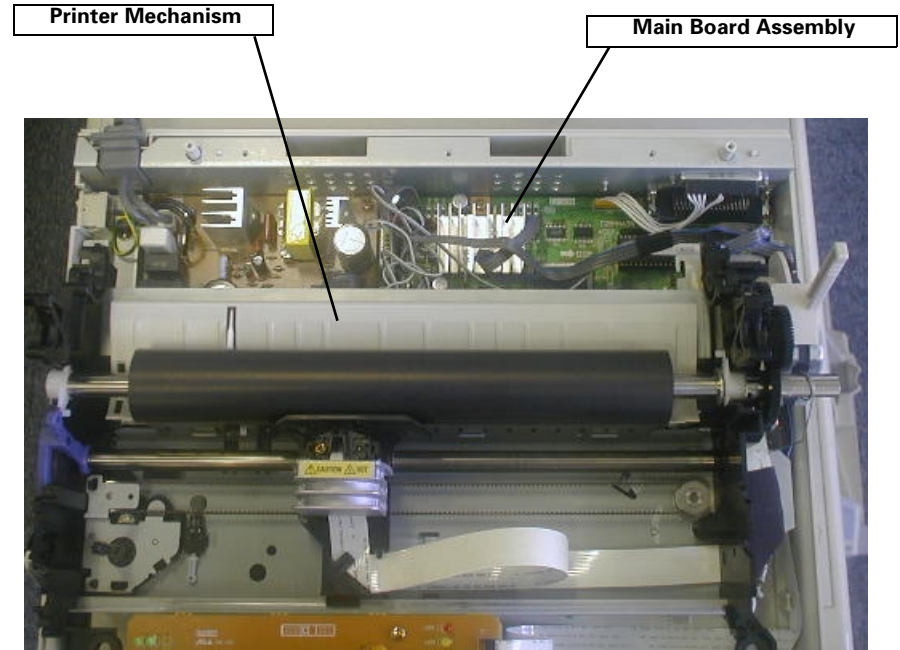

Figure4-4. Harness Removal

5. Remove the printer mechanism.



Perform Bi-D adjustment after removing the printer mechanism.

dis06

dis07

4.2.4 Board Assembly and Panel Removal

1. Remove the upper housing. (See 4.2.2 "Upper Housing Removal".)
2. Remove the panel FFC from the connector of panel board assembly.
3. Remove 3 screws (CBP, 3x10) securing the panel board assembly to the lower housing.
4. Remove the panel board assembly from the lower housing.

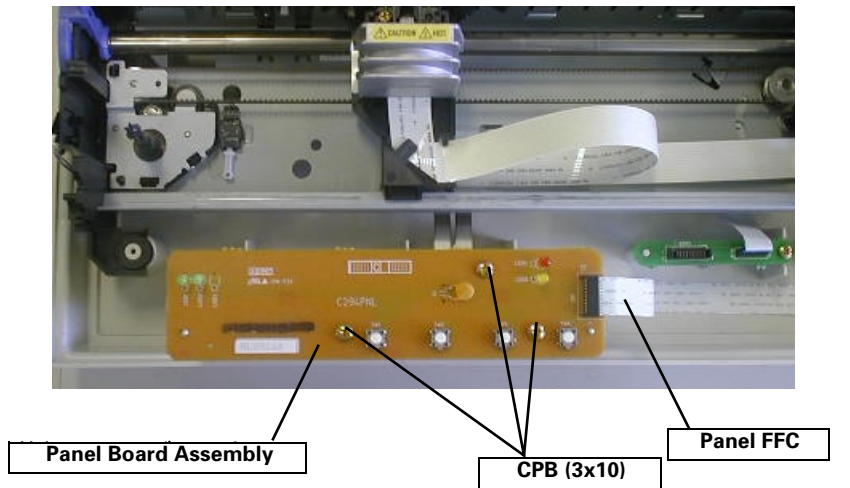

dis08

Figure4-5. Board Assembly and Panel Removal

4.2.5 C294MAIN Board Assembly Removal

1. Remove the upper housing. (See 4.2.2 "Upper Housing Removal".)
2. Remove the printer mechanism. (See 4.2.3 "Printer Mechanism Removal".)
3. Remove 2 hexagon nuts securing the serial interface connector to the lower shield plate.
4. Remove the serial interface connector from the installation hole of the lower shield plate.
5. Remove 2 CP (M3x6) securing the parallel interface to the lower shield plate.
6. Remove the option FFC and panel FFC from CN12 and CN13 on the board.
7. Remove the harness from the P/S board assembly from CN8.
8. Remove 3 screws (CBP, 3x10) securing the main board assembly to the lower housing.



When the main board assembly is replaced, perform destination setting and Bi-D adjustment.

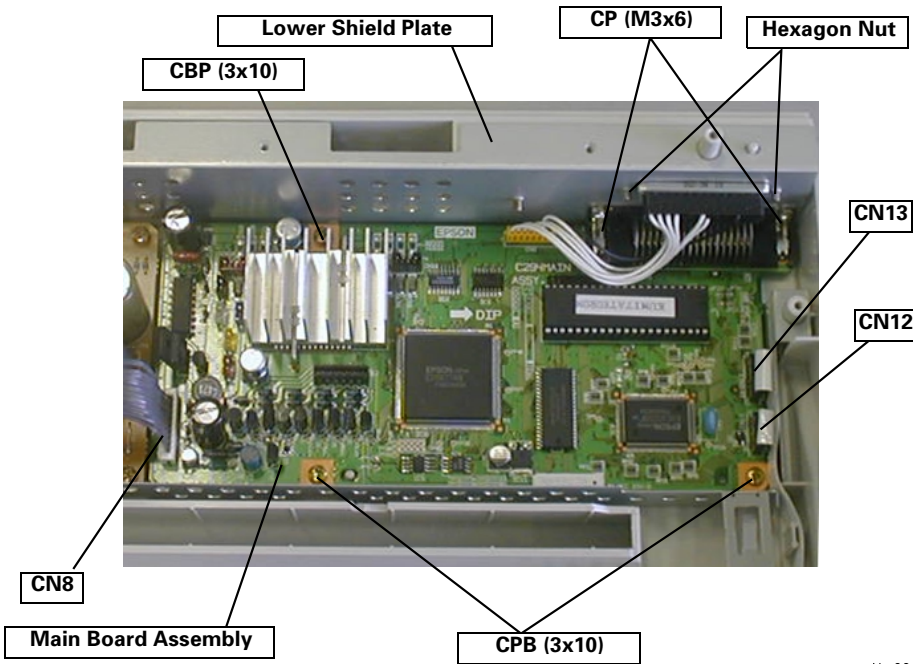

Figure4-6. C294MAIN Board Assembly Removal

dis09

4.2.6 P/S Board Assembly Removal

1. Remove the upper housing. (See 4.2.2 "Upper Housing Removal".)
2. Remove the printer mechanism. (See 4.2.3 "Printer Mechanism Removal".)
3. Remove the power cable (CN1) connecting to the P/S board assembly.
4. Remove the power switch from the lower housing.
5. Remove the harness connecting P/S board assembly to the main board assembly. (CN8 of the main board assembly)
6. Remove 4 screws (CBP, 3x10) securing P/S board assembly to the lower housing.
7. Remove P/S board assembly.

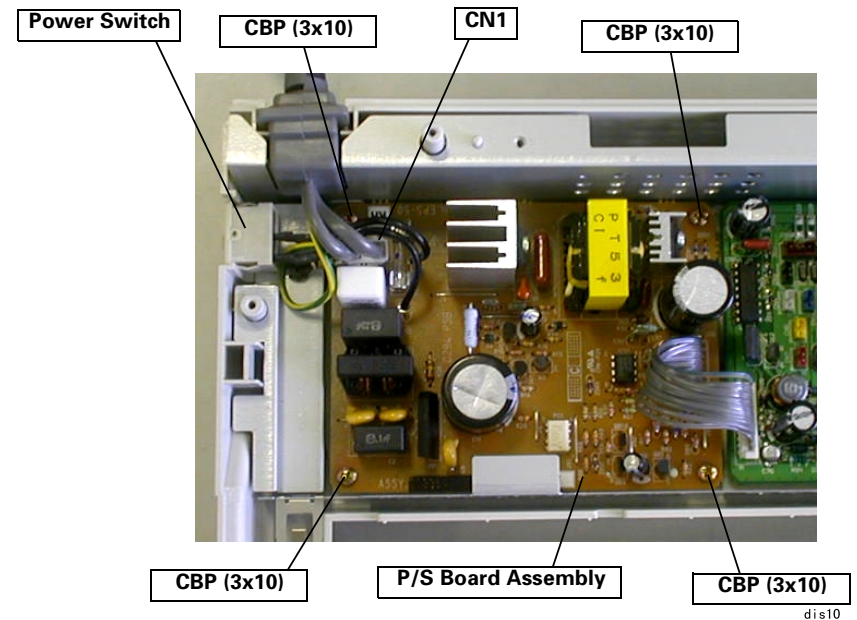

Figure4-7. P/S Board Assembly Removal

dis10

4.2.7 Printer Mechanism Disassembly

This section explains the disassembling procedure of the printer mechanism. The disassembling procedure is shown in the flowchart below.

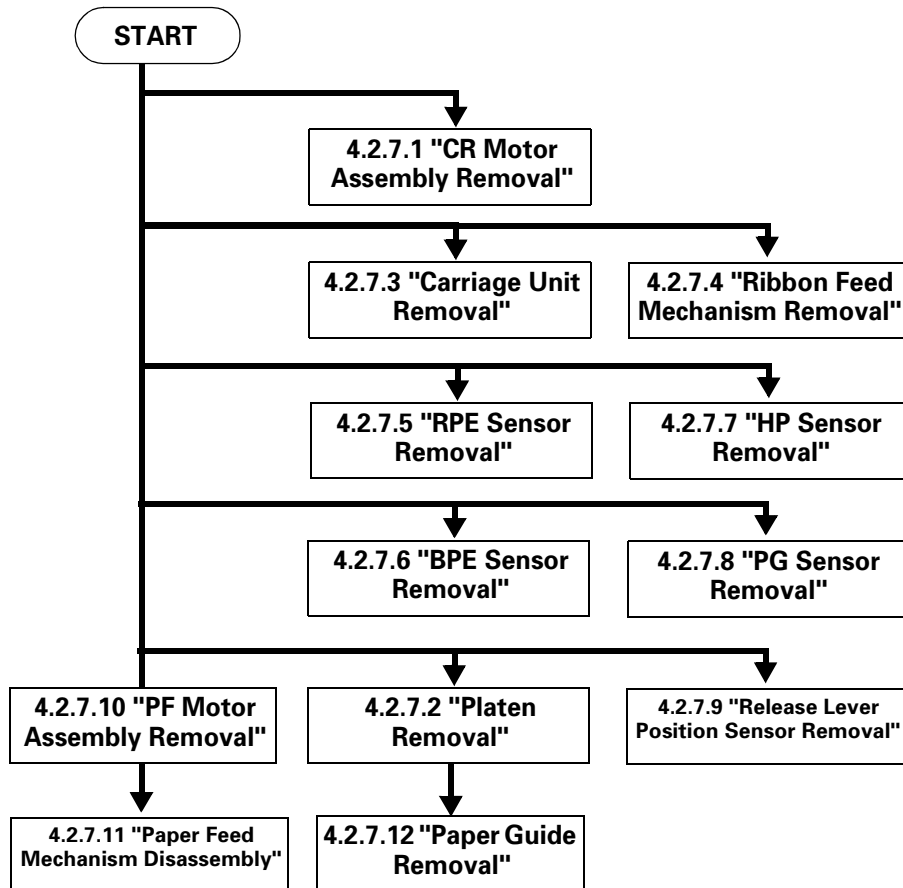
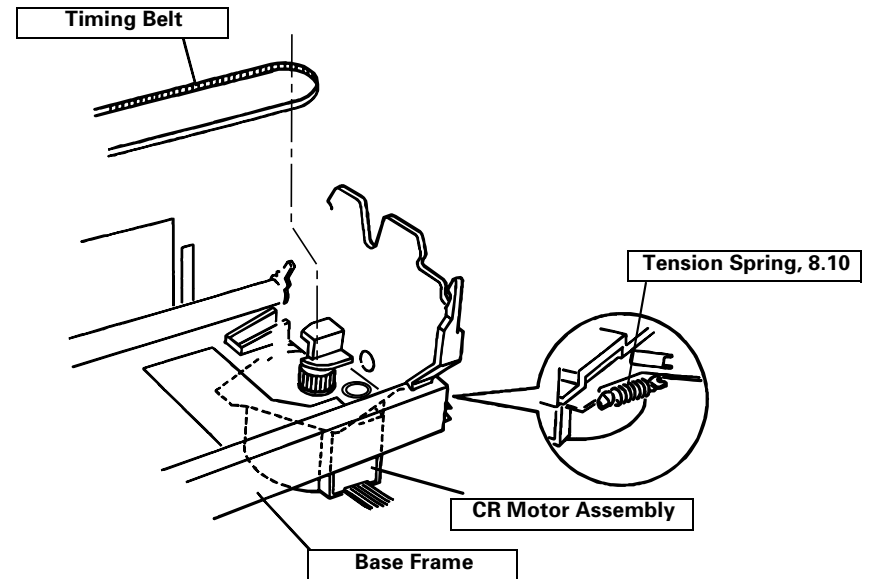

Figure4-8. Printer Mechanism Disassembling Procedure

4.2.7.1 CR Motor Assembly Removal

1. Remove the printer mechanism. (See 4.2.3 "Printer Mechanism Removal".)
2. Remove the tension spring, 8.10 and motor bracket and release the tension of the timing belt.
3. Remove the timing belt from the pulley of the CR motor assembly.
4. Rotate the CR motor assembly with the motor bracket clockwise to remove it.



dis14

Figure4-9. CR Motor Assembly Removal



When the CR motor assembly is replaced, perform Bi-D adjustment.

4.2.7.2 Platen Removal

1. Remove the printer mechanism. (See 4.2.3 "Printer Mechanism Removal".)
2. Remove the platen grounding wire from the platen.
3. Release 1 hook at the rotating hole of the combination gear 17.5, 27 and remove the gear from the right frame.

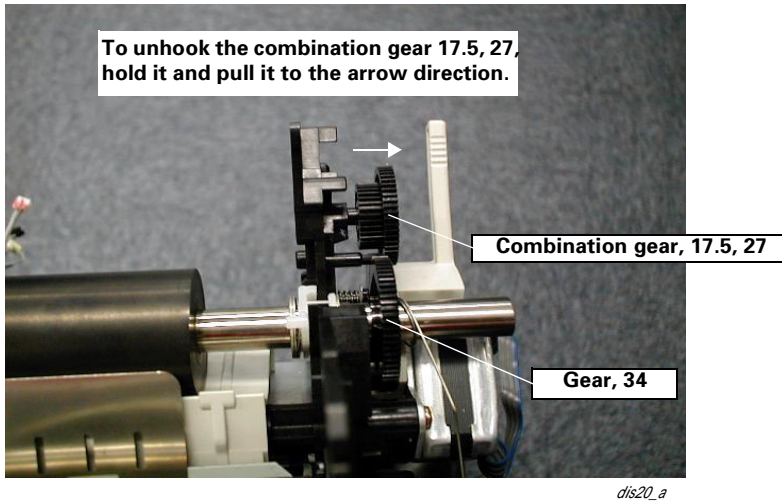

Figure4-10. Hook at the Combination Gear 17.5, 27

4. Rotate right and left bushing, 11 and remove them off from the right / left frame.
5. Remove the platen.

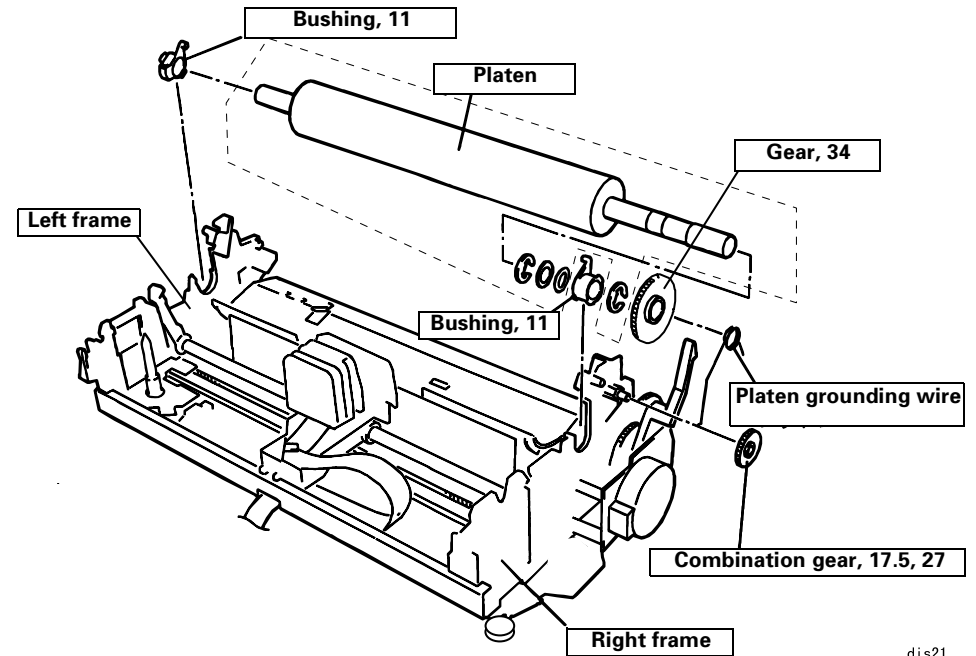

Figure4-11. Platen Removal

4.2.7.3 Carriage Unit Removal

1. Remove the printer mechanism. (See 4.2.3 "Printer Mechanism Removal".)
2. Remove the printhead. (See 4.2.1 "Printhead Removal".)
3. Remove the timing belt from the carriage installation point.

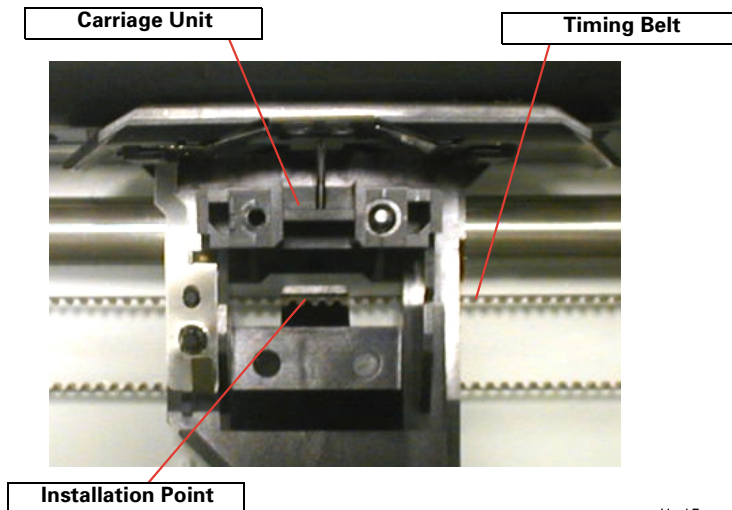

Figure4-12. Timing Belt Removal

4. Remove the CR shaft grounding plate from the base frame on the left side of the printer.

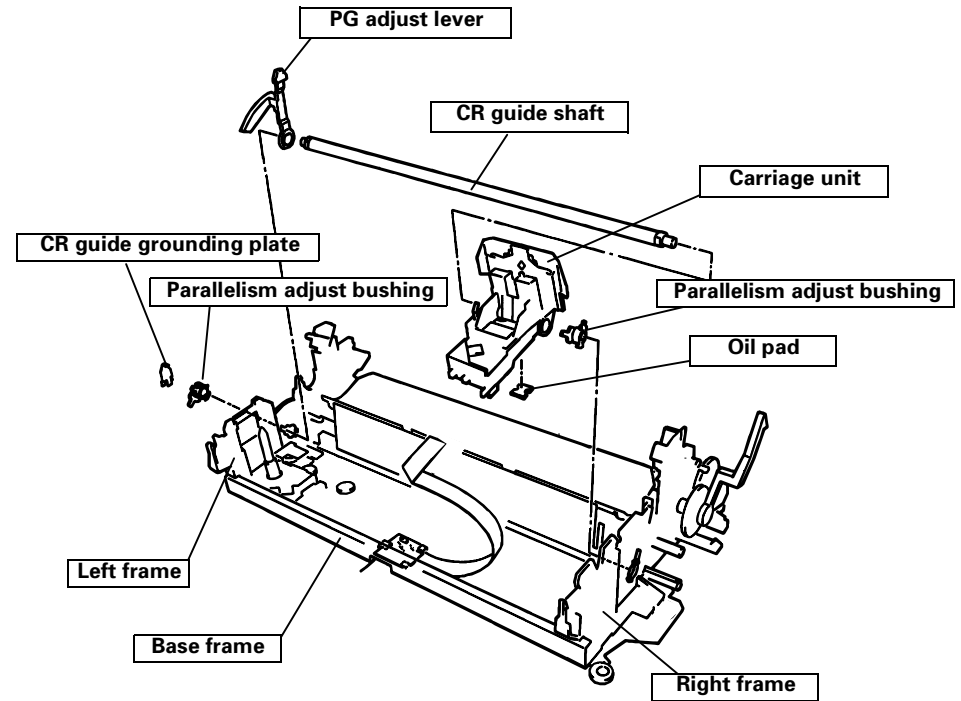
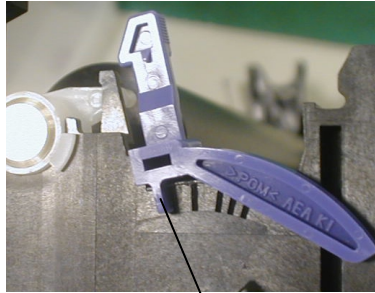

Figure4-13. Carriage Unit Removal

5. Rotate the right and left parallelism adjust bushing and remove them from respective frame.
6. Release the PG adjust lever hook, connecting to the left frame.



PG Adjust Lever -- Hook

dis17

Figure4-14. Hook at the PG Adjust Lever

7. Remove the carriage unit along with the CR guide shaft and PG adjust lever from the printer mechanism.



When the carriage unit is replaced, perform Bi-D adjustment.

4.2.7.4 Ribbon Feed Mechanism Removal

1. Remove the printer mechanism. (See 4.2.3 "Printer Mechanism Removal".)
2. Remove the tension spring, 8.10 from the motor bracket and release the tension of the timing belt. (See 4.2.7.1 "CR Motor Assembly Removal".)
3. Release 3 hooks securing the RD cover to the left frame.
4. Remove the RD cover.

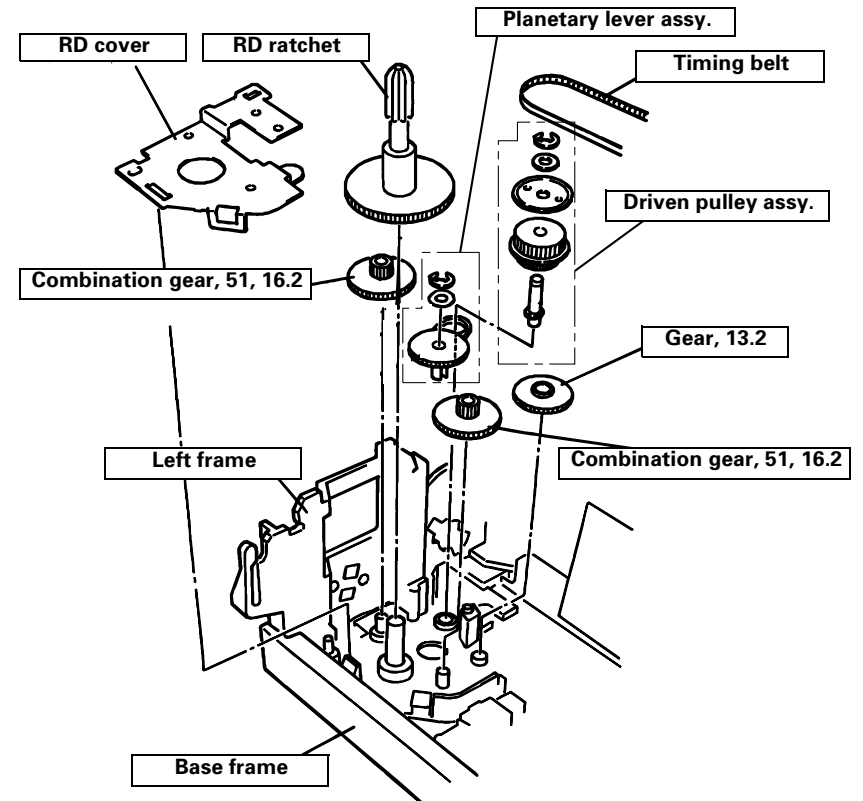

dis12

Figure4-15. Ribbon Feed Mechanism Removal

4.2.7.5 RPE Sensor Removal

1. Remove the printer mechanism. (See 4.2.3 "Printer Mechanism Removal".)
2. Remove the hook of the RPE sensor installed at the paper guide.
3. Remove RPE sensor.
4. Remove the harness from the RPE sensor (white).

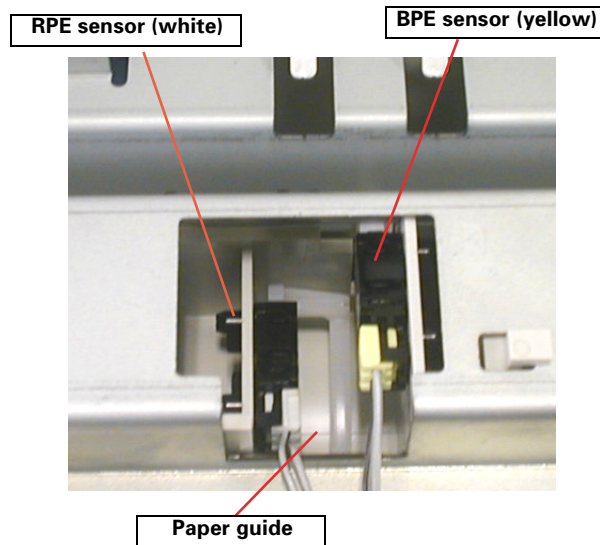

dis18

Figure4-16. RPE/BPE Sensor Removal

4.2.7.6 BPE Sensor Removal

1. Remove the printer mechanism. (See 4.2.3 "Printer Mechanism Removal".)
2. Remove the hook of the BPE sensor installed at the paper guide.
3. Remove BPE sensor.
4. Remove the harness from the BPE sensor (yellow).

4.2.7.7 HP Sensor Removal

1. Remove the printer mechanism. (See 4.2.3 "Printer Mechanism Removal".)
2. Release 2 hooks of the HP sensor securing it to the base frame with tweezers and remove the sensor.
3. Remove the harness from the sensor (black).

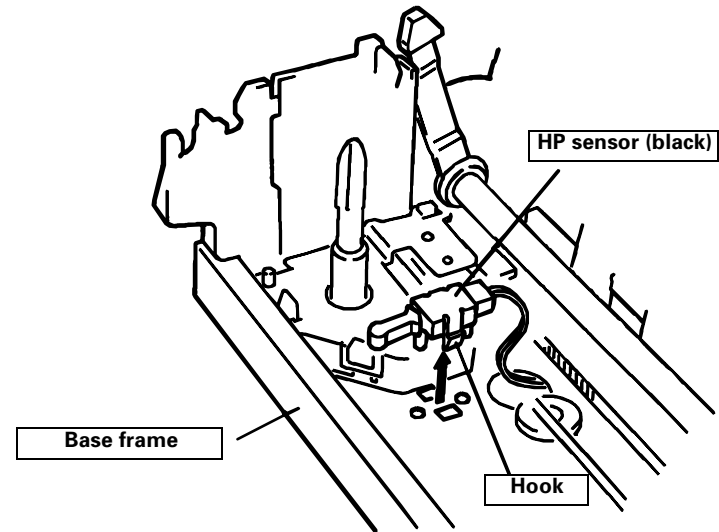

Figure4-17. HP Sensor Removal

4.2.7.8 PG Sensor Removal

1. Remove the printer mechanism. (See 4.2.3 "Printer Mechanism Removal".)
2. Release 2 hooks of the PG sensor securing it to the left frame with tweezers and remove the sensor.
3. Remove the harness from the sensor (white).

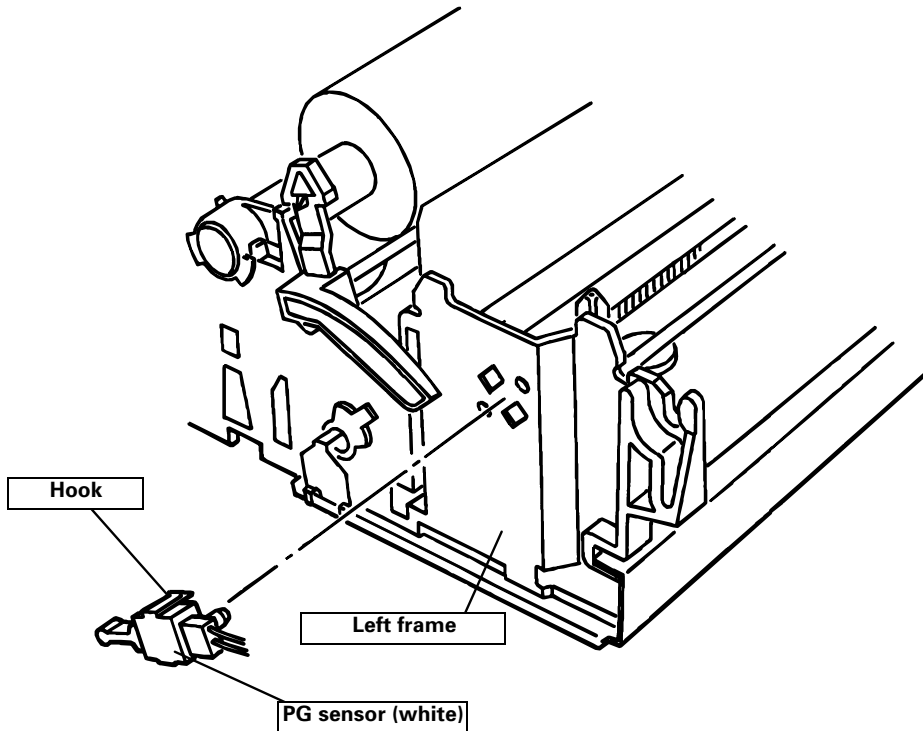
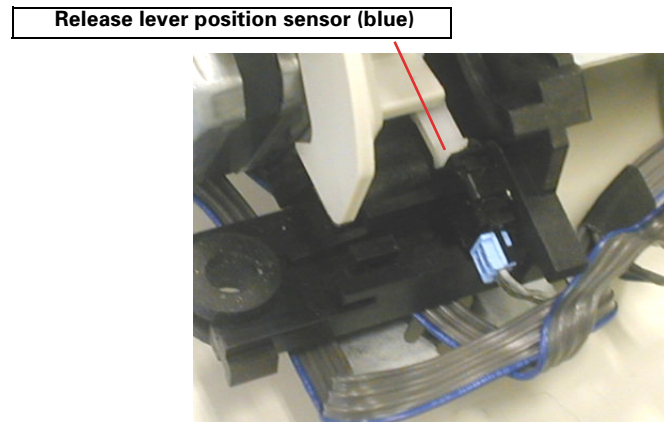

Figure4-18. PG Sensor Removal

dis11

4.2.7.9 Release Lever Position Sensor Removal

1. Remove the printer mechanism. (See 4.2.3 "Printer Mechanism Removal".)
2. Release 2 hooks of the release lever position sensor securing it to the right frame with tweezers and remove the sensor.
3. Remove the harness from the sensor (blue).



dis19

Figure4-19. Release Lever Position Sensor Removal



When installing the release lever position sensor, be sure to insert it between the release lever and the right frame.

4.2.7.10 PF Motor Assembly Removal

1. Remove the printer mechanism. (See 4.2.3 "Printer Mechanism Removal".)
2. Remove the platen grounding wire from the platen.
3. Remove 1 screw (CBP, 3x10) securing the PF motor assembly to the right frame.
4. Remove 1 hook at the right frame securing the PF motor assembly to the right frame and remove the PF motor assembly.

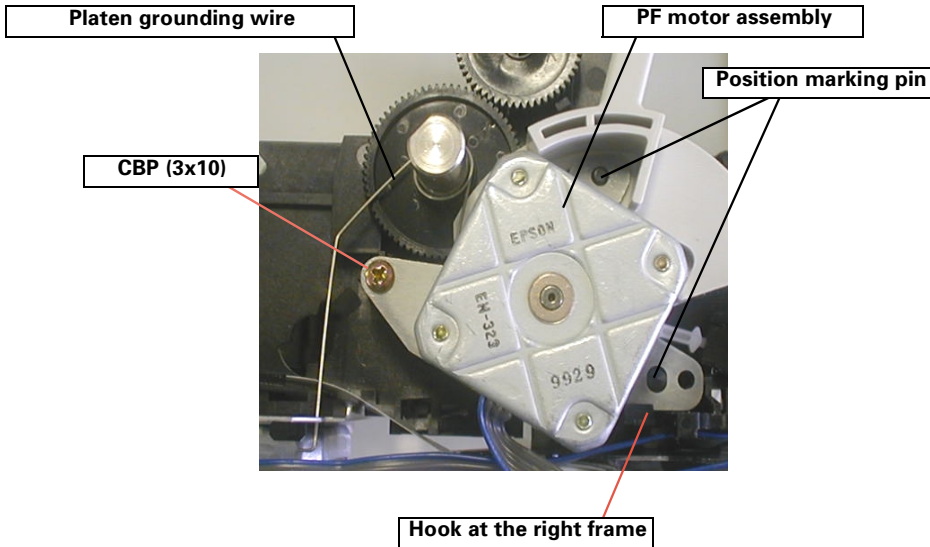

Figure4-20. PF Motor Assembly Removal

dis20



When installing the PF motor assembly to the right frame, be careful to align the position marking pin and motor bracket position marking hole.

4.2.7.11 Paper Feed Mechanism Disassembly

1. Remove the printer mechanism. (See 4.2.3 "Printer Mechanism Removal".)
2. Remove the PF motor assembly. (See 4.2.7.10 "PF Motor Assembly Removal".)
3. Remove the release lever.

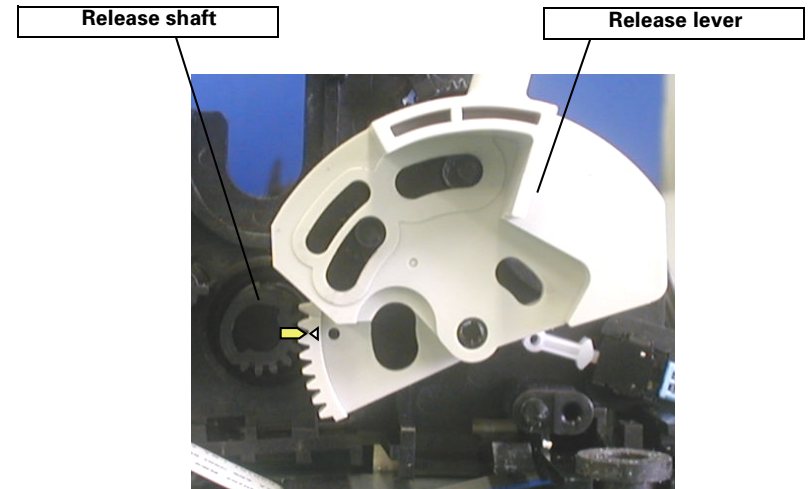

dis22

Figure4-21. Release Lever Removal



When installing the release lever, be sure to align the marking on the release lever with the marking on the release shaft.

4. Release the hook of the right frame securing the gear, 27.5 and remove the gear, plain washer 5.2x0.3x10 and the compression spring, 1.18.

5. Remove the combination gear, 8.5, 25.2 from the right frame.

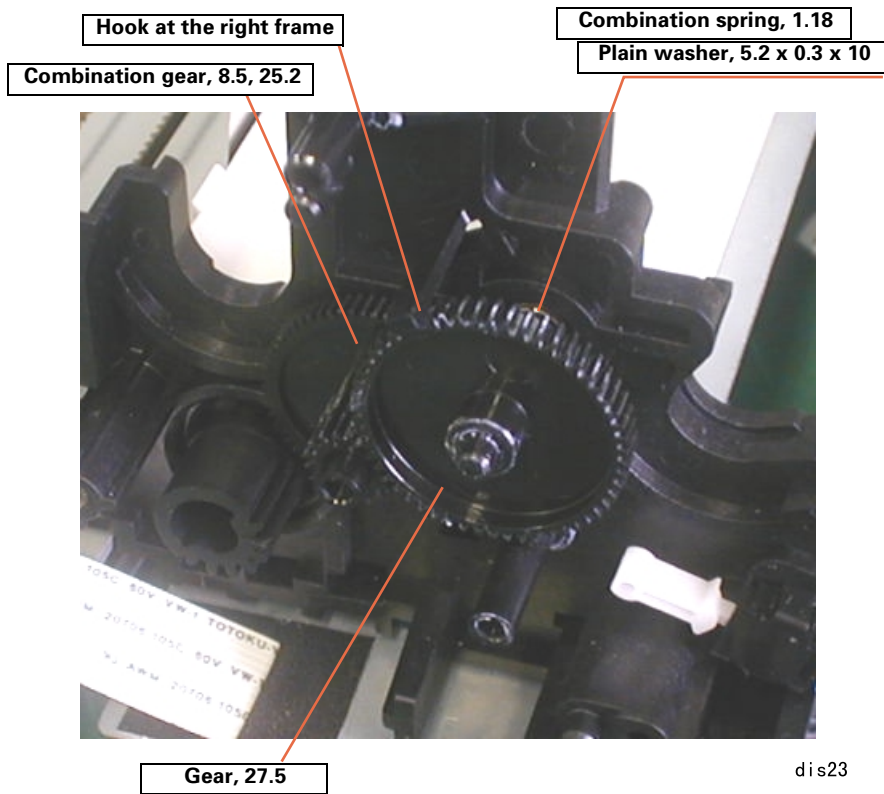

Figure4-22. Paper Feed Mechanism Disassembly

4.2.7.12 Paper Guide Removal

1. Remove the printer mechanism. (See 4.2.3 "Printer Mechanism Removal".)
2. Remove the platen. (See 4.2.7.2 "Platen Removal".)
3. Remove the carriage unit. (See 4.2.7.3 "Carriage Unit Removal".)
4. Remove the HP sensor. (See 4.2.7.7 "HP Sensor Removal".)
5. Remove the PG sensor. (See 4.2.7.8 "PG Sensor Removal".)
6. Remove the PF motor assembly and release lever. (See 4.2.7.10 "PF Motor Assembly Removal".)
7. Release 1 hook securing the paper guide to the bottom of the paper guide to the lower paper guide, pull the paper guide to the rear and remove it.

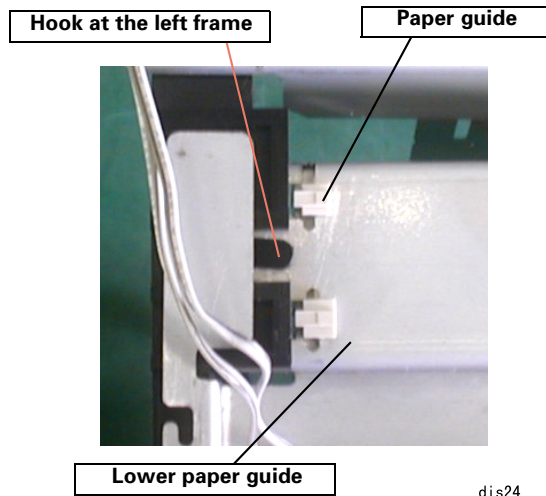

Figure4-23. Lower Paper Guide Removal

8. Release 1 hook at the left frame securing the base frame and remove it by pulling it to the rear.

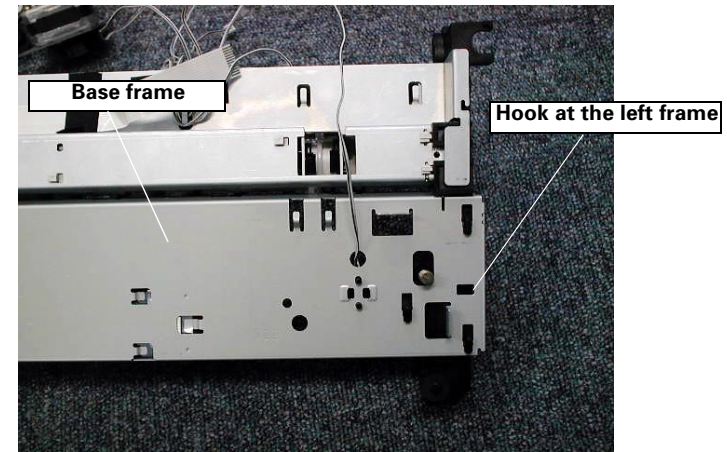

Figure4-24. Left Frame Removal

9. Release 1 hook securing the paper guide to the lower paper guide and remove the paper guide along with the release shaft by pulling it to the left.

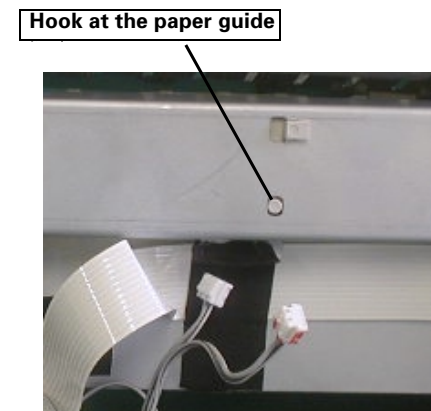

Figure4-25. Lower Paper Guide

CHAPTER

5

ADJUSTMENT

5.1 Overview

This chapter explains the adjustment required after disassembling the printer.

5.1.1 Platen Gap Adjustment

Platen gap adjustment is required at the following cases.

- Printhead is replaced.
- Carriage is replaced.
- CR guide shaft is removed.
- Parallelism adjust bushing is removed.
- Printing is too thin.
- Ink ribbon often gets jammed.

Follow the steps below before performing the platen gap adjustment.

1. Remove the upper housing. (Refer to Ch4.)
2. Set the PG adjust lever to "0".
3. Remove the printhead and remove the ribbon mask.
4. Re-install the printhead.
5. Follow the procedure in the flowchart below for the adjustment.

Table 5-1. Adjustment Method

Platen Gap Setting	Judging Method
0455 ± 0.015mm (TBD)	Thickness gauge 0.44mm falls down by its own weight: ○ Thickness gauge 0.47mm does NOT fall down by its own weight: X

Table 5-2. Parallelism Adjust Bushing

Rotational direction of the parallelism adjust bushing	Platen gap
Platen side	Widen
Front side	Narrowed

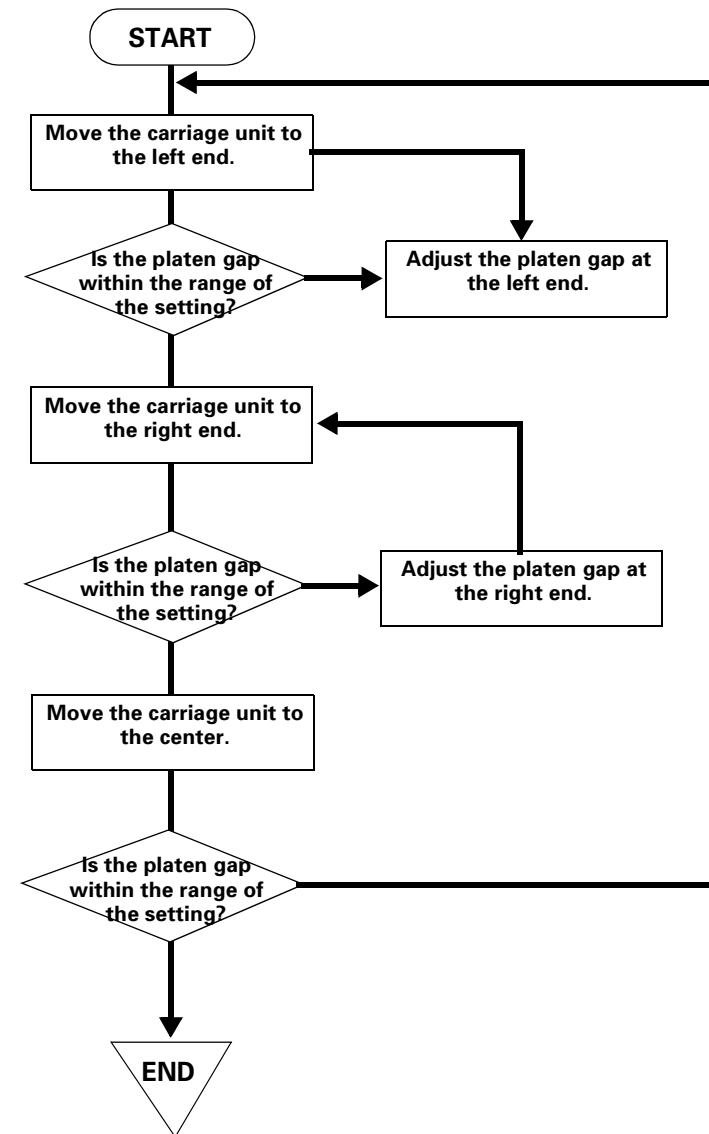

Figure5-1. Platen Gap Adjustment

5.1.2 Bi-D Adjustment

Bi-D adjustment is required at the following cases.

- Main board assembly is replaced.
- Printer mechanism is replaced.
- Printer mechanism is removed.

Follow the steps below for the platen gap adjustment.

1. Connect the printer and the host computer by parallel interface cable.
2. Turn on the PC and the printer.
3. Set FF paper to the printer.
4. Insert FD that contains the adjustment program and click "GW BASIC.EXE" in the disk to execute GWBASIC. The following DOS prompt screen appears.

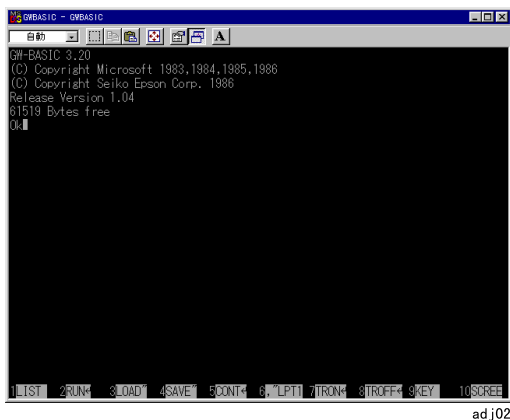

5. Load and run the adjustment program "Q80A10V.bas"

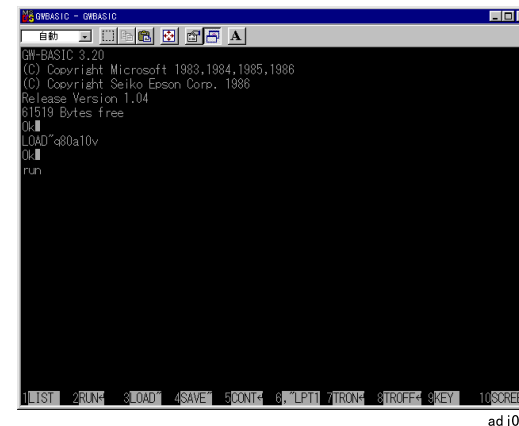

6. The application select screen appears. Input "G" to select "GWBASIC"



- The program will ask you the production line No. Ignore it and press ENTER.

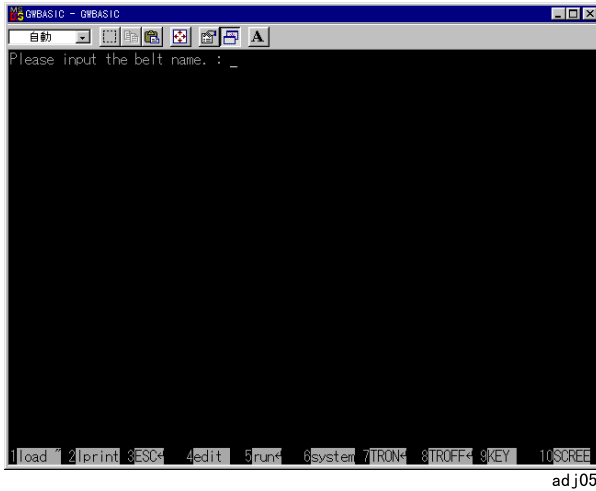

- Printer 9/24 pin select screen appears. Use ↑ and ↓ key to shift ">" mark to the left of "(1) 9 pin" and press ENTER to select 9 pin printer.

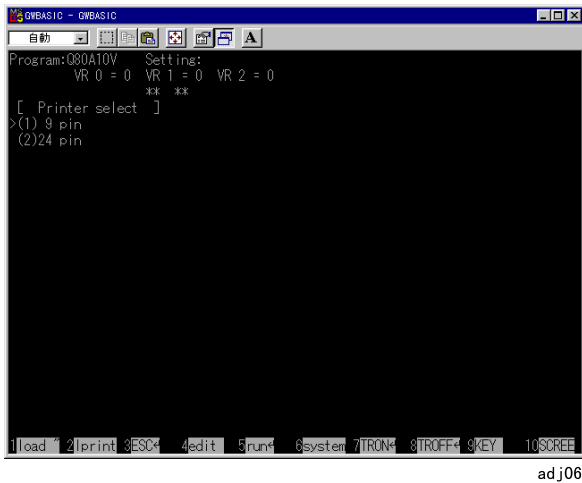

- The destination setting menu appears. Perform settings accordingly.

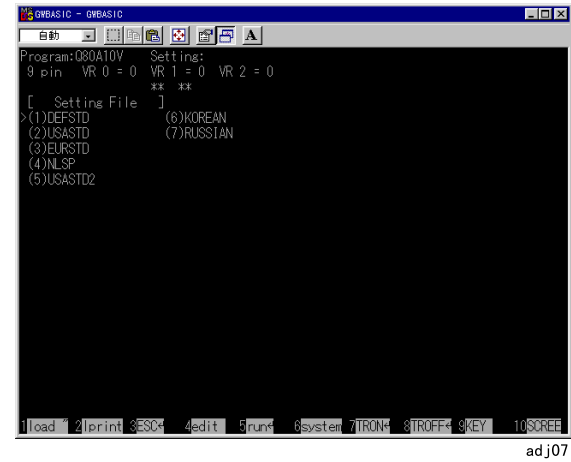

The current destination settings are as follows.

Table 5-3. Destination Setting List (TBD)

Destination	Setting	Destination	Setting
EAI, EAI (Latin)	USASTD	EDG(NLSP)	NLSP
EURO, EDG, EUL, EUL (SCANDINAVIA), EFS, EIS, EIB	EURSTD	EUL (MIDDLE EAST), EAL, ESP, EHK	DEFSTD

- Use ↑ and ↓ key or ← and → key to shift ">" mark to the left of the appropriate destination and press ENTER to select destination.

11. When you select the destination, select menu below appears. You can select from inspection within the production line (In line) or inspection for shipment (Out Going). Use ↑ and ↓ key to shift ">" mark to the left of "Out Going" and press ENTER.

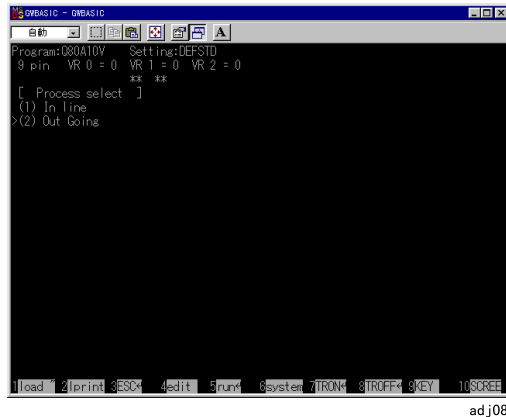

12. On the next screen, you can input the number of printing columns per one movement of the carriage. As the carriage width of LX-300+ is 80, use ↑ and ↓ key to shift ">" mark to the left of "(1) 80 column" and press ENTER.

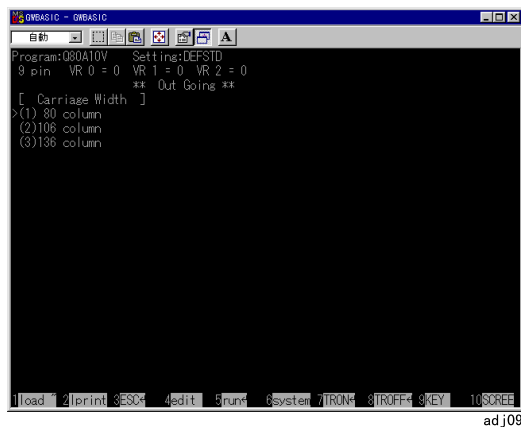

13. "Main MENU" appears. Use ↑ and ↓ key or ← and → key to shift ">" mark to the left of "(1) Bi-D Adjust" and press ENTER.

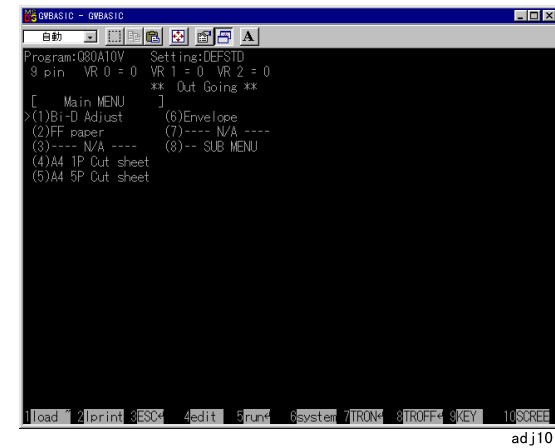

14. The printing mode select menu for Bi-D adjustment appears. Use ↑ and ↓ key to select the printing mode and use ← and → key to select Bi-D setting.

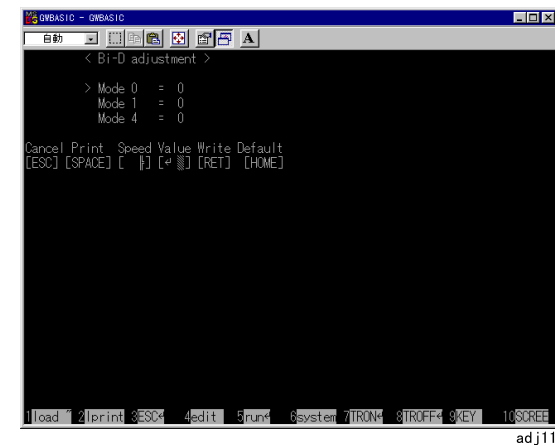

15. Input the printing mode and the settings you want to use and input ENTER (Write) to confirm it. Press space key and the following printing pattern will be printed.

Mode 0 VR0 ≐ 2

Mode 1 VR1 ≐ 0

Mode 4 VR2 ≐ 0

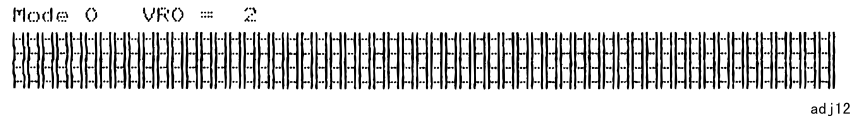

16. Repeat step 14 to 15 until the value "A" shown below goes within the range below for one line for all columns.

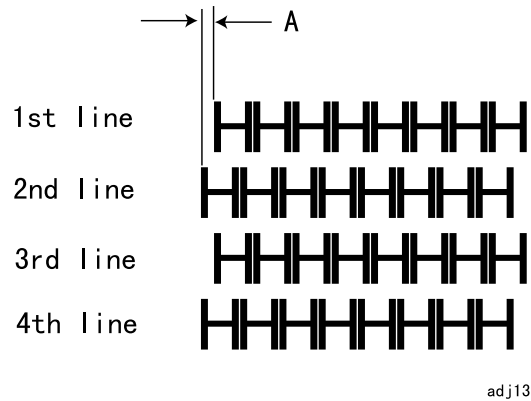

Figure5-2. Bi-D Adjustment Pattern

Table 5-4. Bi-D Rated Setting

Printing Mode	Value "A"
mode 0 (High Speed draft)	TBD
mode 1 (Draft)	TBD
mode 4 (NLQ)	TBD

17. When you finished adjustment, finish the program by pressing "ESC" several times.



- This test program used here is originally the program for production line. Operations that are not described in this manual are forbidden thereafter.
- The adjusted value will not be stored to the EEPROM on the main board assembly until the printer is turned off.
- Clear EEPROM by the panel operation does not clear Bi-D setting.

CHAPTER

6

MAINTENANCE

6.1 Maintenance

Appropriate maintenance is necessary to keep the printer in the best condition and prevent from troubles.

6.1.1 Cleaning

Use neutral detergent or diluted alcohol to clean the dirt on the outside. Vacuum dust or a small piece of papers inside the printer.



- When performing the maintenance, remove the AC cable from the AC socket.
- Never touch the printhead right after printing, as it is highly heated.



- Never use thinner, tricren, or ketone solvent, as it may deform or deteriorate the plastic parts or rubber parts.
- Use the specified amount of the specified oil.

6.1.2 Lubrication

The lubrication point of LX-300+ is as shown in the following table. Refer to the table for the type and the amount of oil to be used for each point. Oil and grease have a great affect on the performance of the product, especially on the durability and the performance at the lower temperature. EPSON determines what kind of and how much of oil to be applied based on the various information and analysis.

Table 6-1. Lubricants

Type	Name	Quantity	Availability	Part No.
Grease	G-26	40g	EPSON	B702600001
Oil	O-2	40cc	EPSON	B710200001

Table 6-2. Lubrication Points

Fig.	Lubrication Points	Lubricant	Quantity
6-1	3 shafts and 2 bosses of the left frame	G-26	1/2 grain of rice
	Shaft of RD ratchet	G-26	1 grain of rice
6-2	Teeth of Gears at the left frame	G-26	1/2 grain of rice
6-3	3 places on the 3 shafts of the right frame	G-26	1 grain of rice
6-4	2 places on inside of cam at slope surface of the release lever	G-26	1 grain of rice
6-5	Shaft of the PF roller drive and the rear driven PF roller.	G-26	1/2 grain of rice
6-6	Paper guide from the back side at 4 places	G-26	1 grain of rice
6-7	Hole of the right tractor assy frame faces to the tractor assy guide shaft and the left TR frame.	G-26	1/2 grain of rice
6-8	Oil pad	O-2	0.28-0.32cc
6-9	Touching parts of the 2 sides of the base frame.	G-26	40mm x 2 places
6-10	2 touching position with the CR motor assembly from the inside of the base frame.	G-26	1/2 grain of rice x 2
6-11	Installing shaft of the combination gear, 17.5, 27 of the right frame.	G-26	1/2 grain of rice
6-12	Touching position of the grounding platen spring with platen shaft.	G-26	1 grain of rice
	Spur gear 34	G-26	10mm

NOTE: Lubrication must be applied during the re-assembly process. For lubrication points, refer to the following figures.

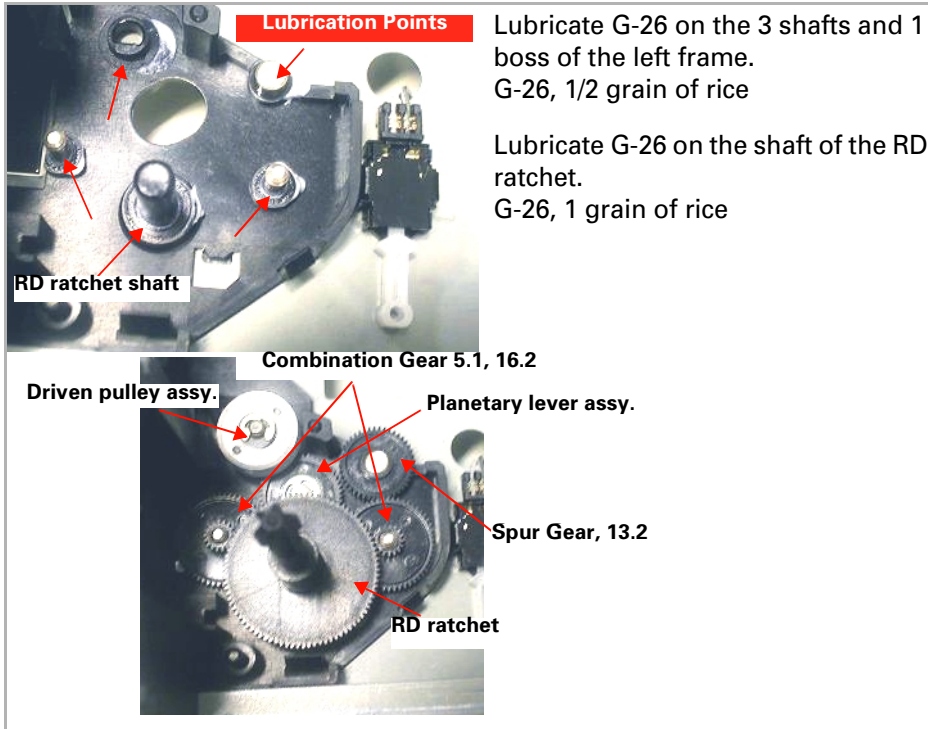

Figure 6-1. Left Frame Assembly

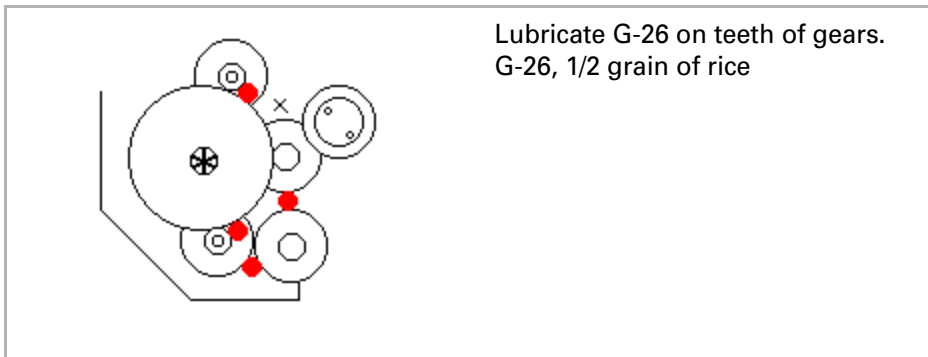

Figure 6-2. Teeth of Gears at the Left Frame

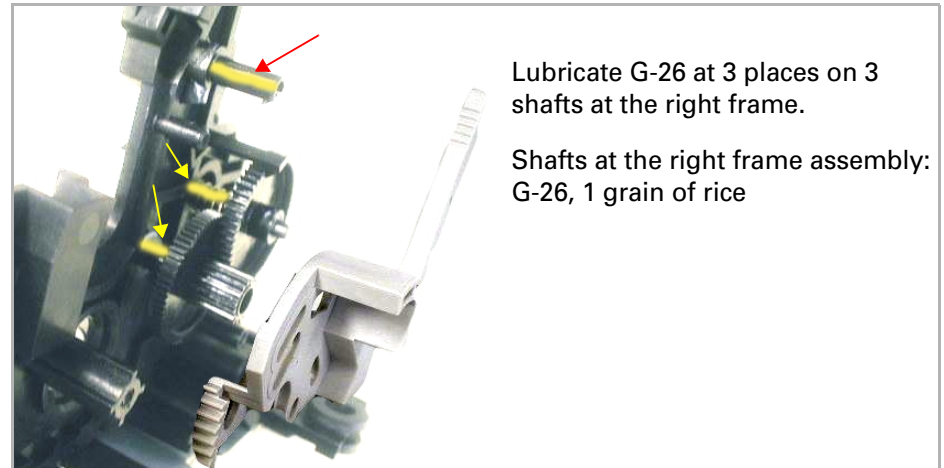

Figure 6-3. Shafts at the Right Frame Assembly

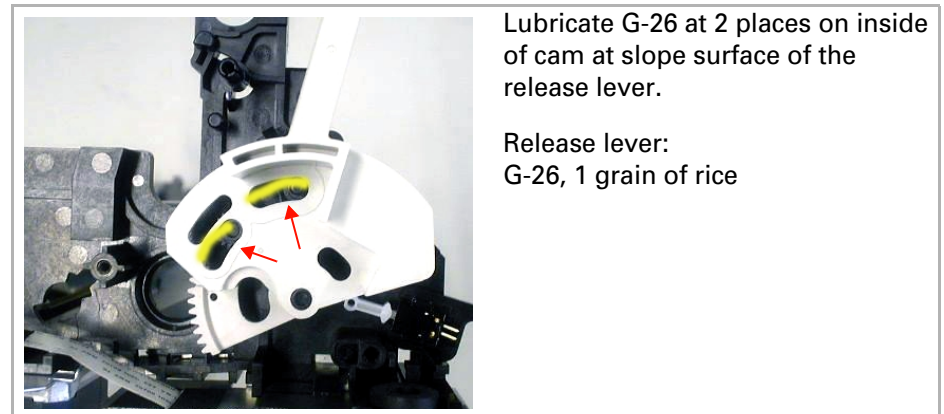
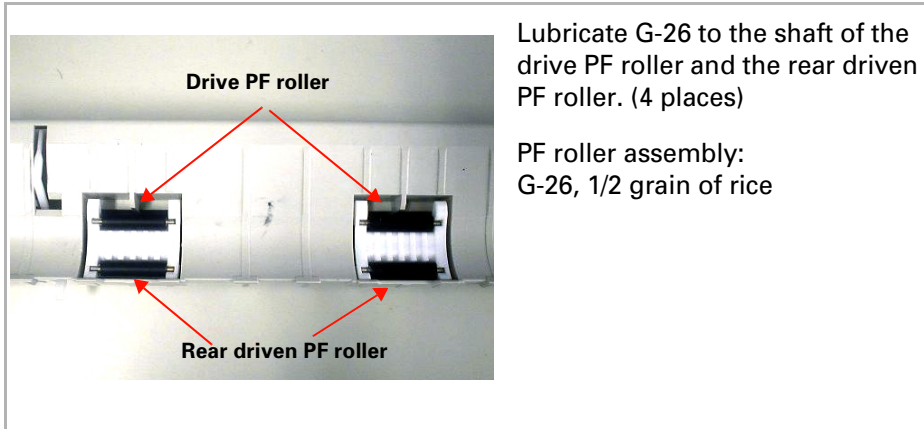

Figure 6-4. Release Lever



Lubricate G-26 to the shaft of the drive PF roller and the rear driven PF roller. (4 places)

PF roller assembly:
G-26, 1/2 grain of rice

Figure 6-5. PF Roller Assembly

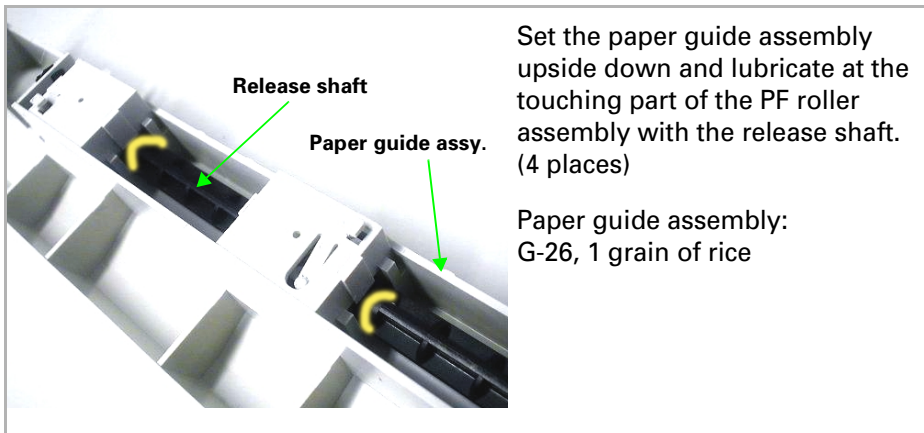

Set the paper guide assembly upside down and lubricate at the touching part of the PF roller assembly with the release shaft. (4 places)

Paper guide assembly:
G-26, 1 grain of rice

Figure 6-6. Paper Guide Assembly

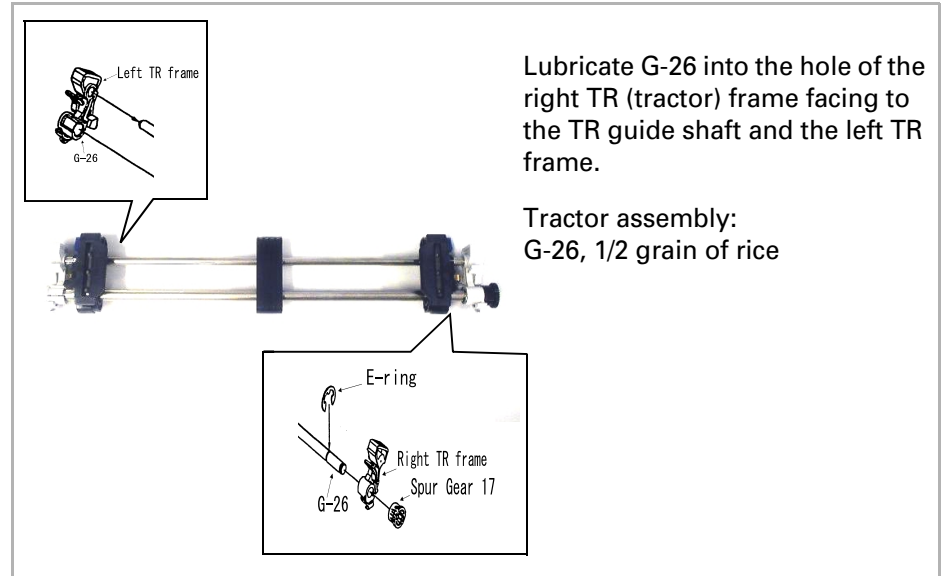

Lubricate G-26 into the hole of the right TR (tractor) frame facing to the TR guide shaft and the left TR frame.

Tractor assembly:
G-26, 1/2 grain of rice

Figure 6-7. Tractor Assembly

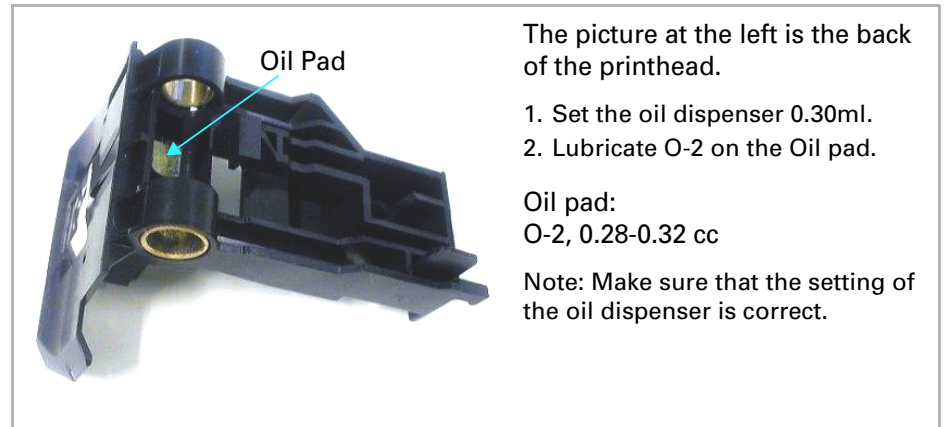

The picture at the left is the back of the printhead.

1. Set the oil dispenser 0.30ml.
2. Lubricate O-2 on the Oil pad.

Oil pad:
O-2, 0.28-0.32 cc

Note: Make sure that the setting of the oil dispenser is correct.

Figure 6-8. Oil Pad



Move the carriage around the center, then lubricate G-26 on the touching parts of the 2 sides of the frame.

Carriage:
G-26, 40mm x 2 places

Figure 6-9. Carriage

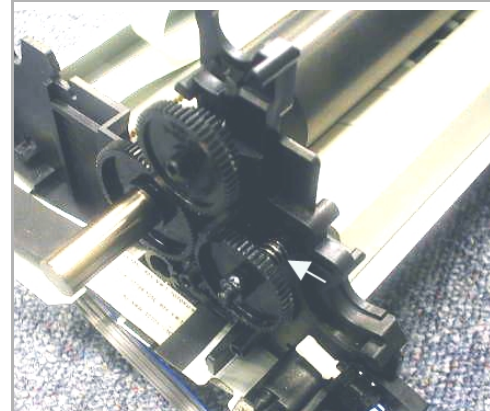

Lubricate G-26 on the installing shaft of the Combination Gear, 17.5, 27 of the right frame.

Combination gear 17.5, 27:
G-26, 1/2 grain of rice

Figure 6-11. Combination Gear 17.5, 27

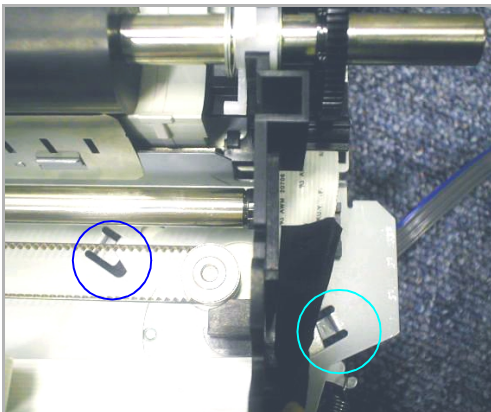

Lubricate G-26 on the 2 touching position with CR motor assembly from the inside of the base frame.

CR motor assembly:
G-26, 1/2 grain of rice x 2

Figure 6-10. CR Motor Assembly



Lubricate G-26 to the touching position of the platen grounding spring with Platen shaft and the spur gear 34.

Platen grounding spring:
G-26, 1 grain of rice.

Spur Gear:
G-26, 10mm

Figure 6-12. Platen Grounding Spring / Spur Gear

CHAPTER

7

APPENDIX

7.1 Connector Summary

The figure below illustrates how the primary components are connected.

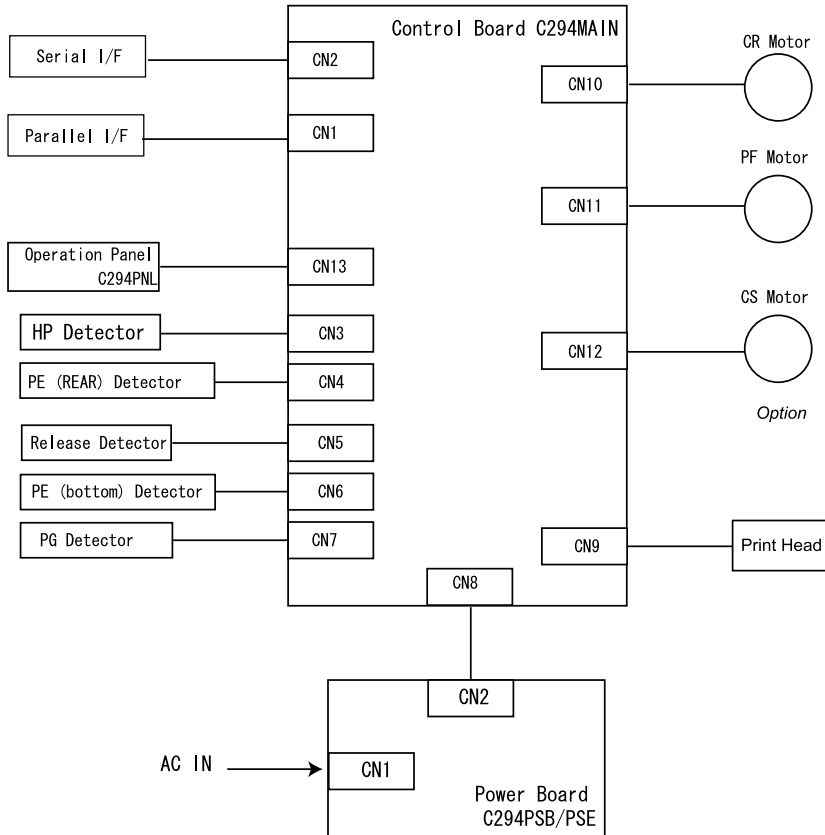

Figure 7-1. Cable Connections

app01

Table 7-1. C294MAIN Board Connector Summary

Connector	Function	Pins
CN1	Parallel I/F	36
CN2	Serial I/F	6
CN3	HP Detector	2
CN4	PE (Rear) Sensor	2
CN5	Release Detector	2
CN6	PE (bottom) Detector	2
CN7	PG Detector	2
CN8	Power Board C294PSB/PSE	9
CN9	Printhead	12
CN10	CR Motor	4
CN11	PF Motor	4
CN12	CS Motor (Option)	10
CN13	Operation Panel C294PNL	12

Table 7-2. Connector Pin Assignments - CN3

Pin	I/O	Signal Name	Function
1	I	HP	Carriage home position sensor signal
2	-	GND	Signal ground

Table 7-3. Connector Pin Assignments - CN4

Pin	I/O	Signal Name	Function
1	I	RPE	Rear paper end sensor signal
2	-	GND	Signal ground

Table 7-4. Connector Pin Assignments - CN5

Pin	I/O	Signal Name	Function
1	I	RELEASE	Release sensor signal
2	-	GND	Signal ground

Table 7-5. Connector Pin Assignments - CN6

Pin	I/O	Signal Name	Function
1	I	BPE	Bottom paper end sensor signal
2	-	GND	Signal ground

Table 7-6. Connector Pin Assignments - CN7

Pin	I/O	Signal Name	Function
1	I	PG	Paper gap (copy mode) sensor signal
2	-	GND	Signal ground

Table 7-7. Connector Pin Assignments - CN8

Pin	I/O	Signal Name	Function
1	-	VH	+35VDC
2	-	VH	+35VDC
3	-	GP	Signal ground
4	-	GP	Signal ground
5	O	PSC	Power save control
6	O	POFF	Power off signal
7	-	+5V	+5VDC
8	-	+5V	+5VDC

Table 7-8. Connector Pin Assignments - CN9

Pin	I/O	Signal Name	Function
1	O	HD7	Head data 7
2	O	HD8	Head data 8
3	O	HD9	Head data 9
4	O	HD3	Head data 3
5	-	HDCOM	Common (VP)
6	-	HDCOM	Common (VP)
7	-	HDCOM	Common (VP)
8	O	HD2	Head data 2
9	O	HD9	Head data 9
10	O	HD4	Head data 4
11	O	HD8	Head data 8
12	O	HD6	Head data 6

Table 7-9. Connector Pin Assignments - CN10

Pin	I/O	Signal Name	Function
1	O	CRA	Carriage motor phase A
2	O	CR \bar{A}	Carriage motor phase \bar{A}
3	O	CRB	Carriage motor phase B
4	O	CR \bar{B}	Carriage motor phase \bar{B}

Table 7-10. Connector Pin Assignments - CN11

Pin	I/O	Signal Name	Function
1	O	PFA	Paper feed motor phase A
2	O	PFA \bar{A}	Paper feed motor phase \bar{A}
3	O	PFB	Paper feed motor phase B
4	O	PFB \bar{B}	Paper feed motor phase \bar{B}

Table 7-11. Connector Pin Assignments - CN12

Pin	I/O	Signal Name	Function
1	-	VH	+35VDC
2	-	CS/HOLD	+5VDC
3	-	+5V	+5VDC
4	O	CSA \bar{A}	CS motor phase \bar{A}
5	O	CSXA \bar{A}	CS motor phase $\bar{X}\bar{A}$
6	O	CSB \bar{B}	CS motor phase \bar{B}
7	O	CSXB \bar{B}	CS motor phase $\bar{X}\bar{B}$
8	-	GP	Signal ground
9	I	CSSW	Color ribbon sensor signal
10	-	GND	Signal ground

Table 7-12. Connector Pin Assignments - CN13

Pin	I/O	Signal Name	Function
1	-	+5V	+5VDC
2	O	LED5	LED5
3	O	LED4	LED4
4	O	LED3	LED3
5	O	LED2	LED2

Table 7-12. Connector Pin Assignments - CN13

Pin	I/O	Signal Name	Function
6	O	LED1	LED1
7	I	SW1	Switch 1
8	-	GND	Signal ground
9	-	GND	Signal ground
10	I	SW2	Switch 2
11	I	SW3	Switch 3

7.2 Parts List

The following table shows parts name of this product. Refer to the exploded diagrams for parts' number.

Table 7-13. Parts List

Number	Parts Name
100	"HOUSING ASSY.,LOWER"
101	INSULATOR;A
102	INSULATOR;B
103	"HOUSING,UPPER"
104	"SHIELDPLATE,LOWER"
105	"COVER ASSY.,PRINTER"
106	KNOB;W
109	SHEET GUIDE ASSY.
111	"SHIELDPLATE,UPPER"
115	"COVER CONNECTOR,CS;W"
116	HEXAGON NUT
117	GROUNDINGPLATE
118	"GROUNDING PLATE,PANEL"
119	EDGING;A
120	LOGO PLATE
123	"FERRITE CORE,FPC-25-20"
124	"SHEET,PROTECT"
125	CONNECTOR LOCK NUT
126	RIVET B-TITE(SCREW TYPE)
127	"C.B.P-TITE,3X10,F/ZN"
128	C.B.S. SCREW

Table 7-13. Parts List

Number	Parts Name
129	"C.B.B-TITE(P(13)),3X14,F/ZN"
130	C.B.(O) SCREW 4X8 F/ZG
131	C.P.SCREW
132	C.B.S. SCREW
180	"GUIDE,STACKER"
200	"BOARD ASSY.,MAIN"
320	HARNESS
300	"BOARD ASSY.,POWER SUPPLY"
400	POWER CABLE ASSY.
450	"BOARD ASSY.,PANEL"
451	"SHEET,PANEL"
500	"PRINTER MECHANISM,M-3M10-100"
501	"FRAME,LEFT" (This name is not fixed.)
502	"FRAME,RIGHT"
503	"MOTOR ASSY.,CR"
504	"EXTENSION SPRING,8.10"
505	"LEVER ASSY.,PLANET"
506	"SHAFT,CR,GUIDE"
509	"SPURGEAR,13.2"
510	"COMBINATIONGEAR,5.1,16.2"
511	"MOTOR ASSY.,PF"
512	"COVER,RD"
513	"RATCHET,RD"
514	"DETECTOR,LEAF,B1"
515	"GROUNDING WIRE,PLATEN"

Table 7-13. Parts List

Number	Parts Name
516	"PULLEY ASSY.,DRIVEN"
517	"HARNESS,HP"
518	C.P.B SCREW
520	PAPER GUIDE
521	"DETECTOR,PE,REAR"
522	"HARNESS,PE,REAR"
523	"DETECTOR,PE,BOTTOM"
524	"HARNESS,PE,BOTTOM"
525	"HOLDER,ROLLER,PF"
526	"ROLLER,PF,DRIVEN"
527	"ROLLER,PF,DRIVEN,REAR"
528	"COMPRESSION SPRING,13.72"
529	"SHAFT,RELEASE"
530	PAPER GUIDE ASSY.
531	RETAINING RING
532	"BUSHING,11"
533	"U-TYPE,11.2X0.13X16S/NA"
534	PLAIN WASHER
535	PLATEN
536	CARRIAGE ASSY.
537	"GROUNDING PALTE,HEAD"
538	OIL PAD
539	"LEVER,G,ADJUST"
540	RIBBON MASK
541	TIMING BELT

Table 7-13. Parts List

Number	Parts Name
542	"BUSHING,PARALLEL,ADJUST"
543	"CABLE,HEAD"
544	"HARNESS,PG"
545	"PAPER GUIDE,LOWER"
550	"SPURGEAR,17"
551	PAPERSUPPORT
552	"FRAME,TR,RIGHT"
553	"FRAME,TR,LEFT"
554	"TRACTOR,LEFT"
555	"TRACTOR,RIGHT"
556	"SHAFT,TR,GUIDE"
557	"SHAFT,TR,DRIVE"
558	RETAINING RING
559	DAMPER
560	"FRAME,BASE"
561	"PAPER GUIDE,SUPPORT"
562	"GROUNDING PALTE,SHAFT,CR"
563	"SHEET,CABLE,HEAD"
564	"GEAR,34"
565	"SPUR GEAR,27.5"
566	PLAIN WASHER
567	"COMPRESSION SPRING,1.18"
568	"COMBINATION GEAR,8.5,25.2"
569	"HARNESS,RELEASE"
570	PAPER EJECT ASSY.

Table 7-13. Parts List

Number	Parts Name
571	"COMBINATION GEAR,17.5,27"
573	"GROUNDING PLATE,CS"
574	"GROUNDING WIRE,LEFT"
575	"GROUNDING WIRE,RIGHT"
576	"GROUNDING PLATE,PF"
577	"SHEET,PROTECT,CABLE"
578	"SHEET,PROTECT,M/B"
579	"SHEET,CABLE,CR"
580	"C.B.P-TITE,3X10,F/ZN"
581	C.B.S. SCREW
590	"LEVER,RELEASE"
650	"PRINT HEAD,D3910-1"
651	"LABEL,WARNING"

7.3 Exploded Diagrams

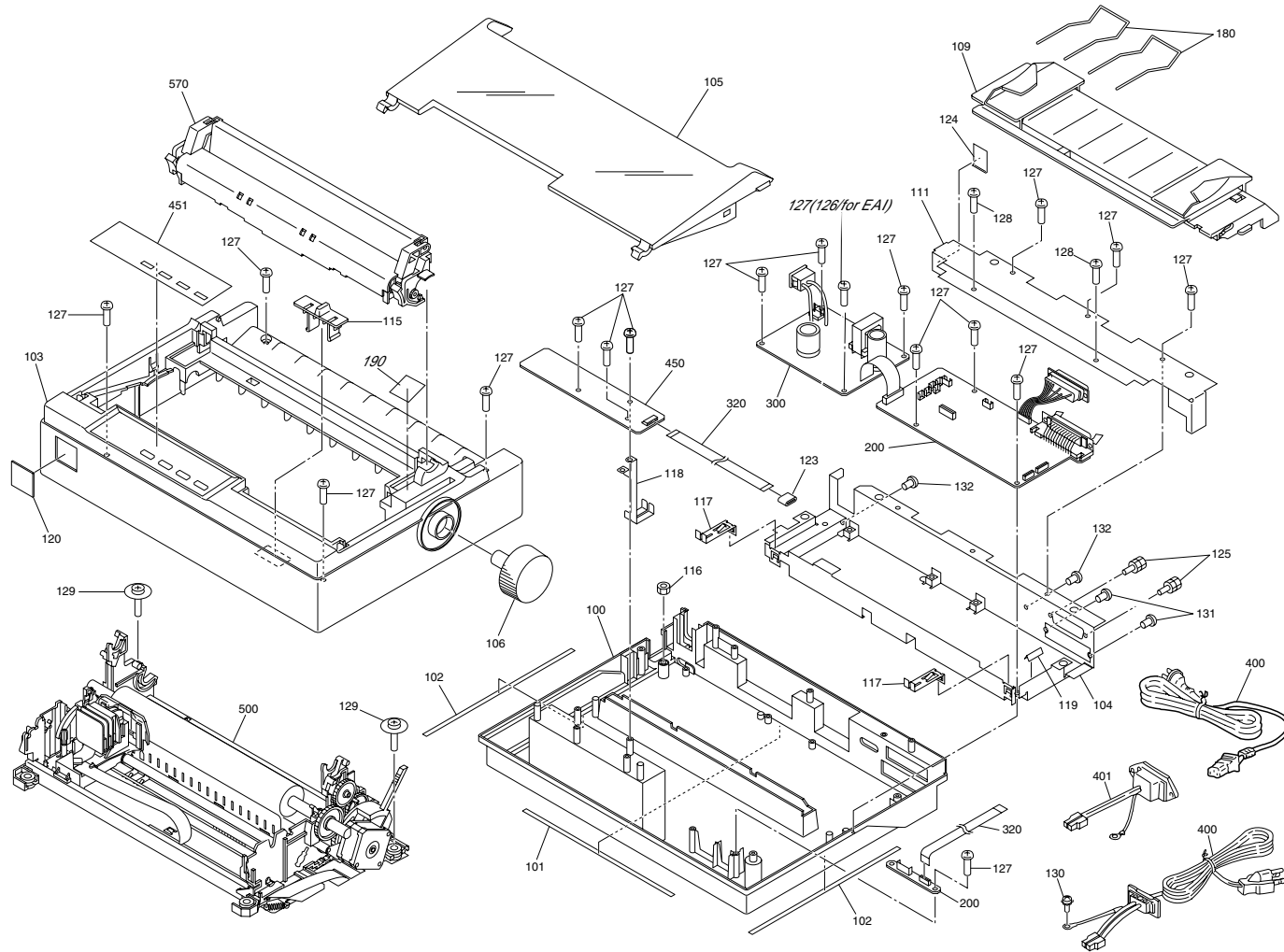

L-300 No.01 Rev.01 10202

Figure 7-2. Exploded Diagram 1

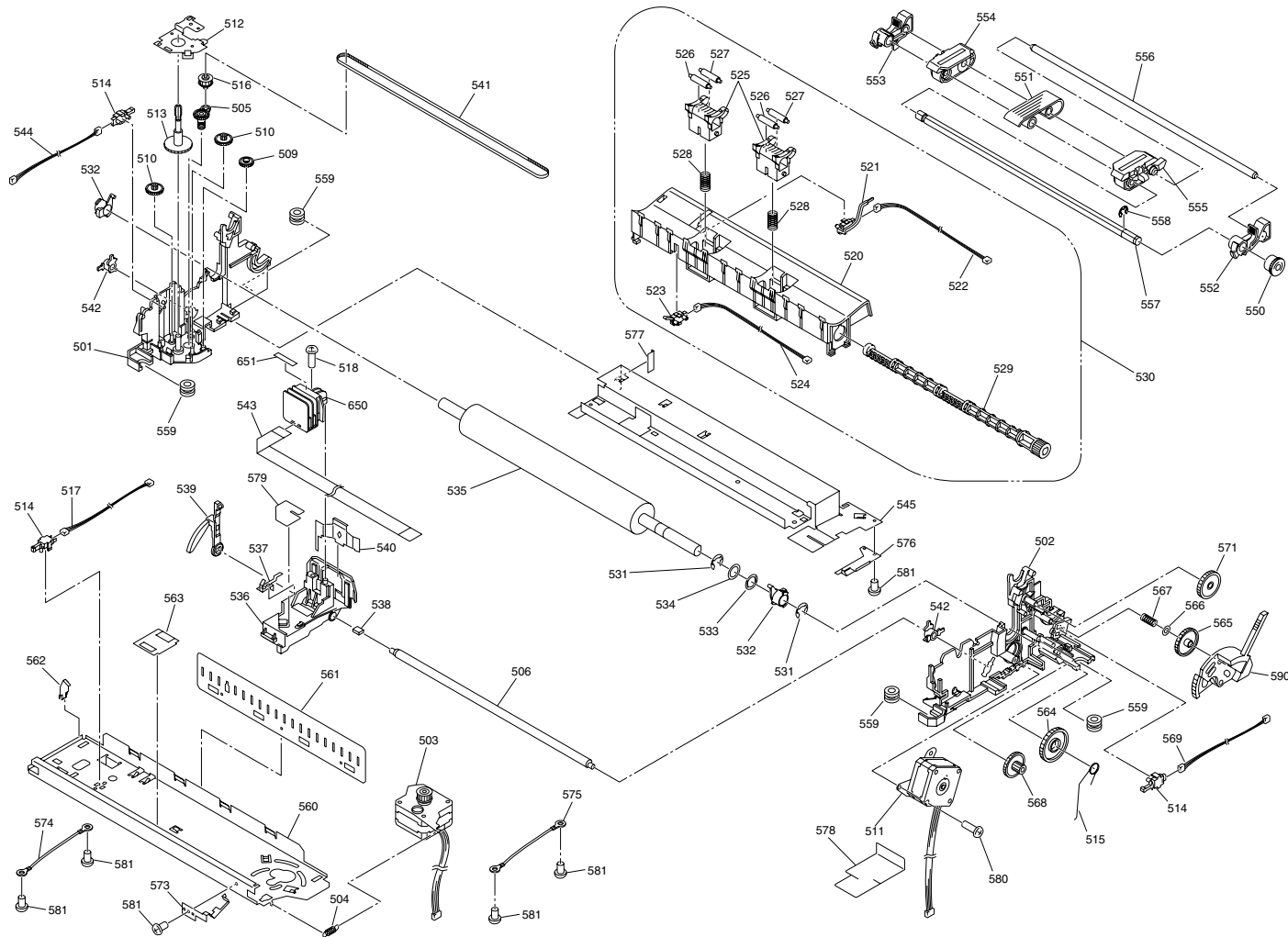

L-300 No.02 Rev.01 10202

Figure 7-3. Exploded Diagram 2

7.4 Component Layout

TBD

7.5 Circuit Schematics

The following pages show circuit schematics below.

- C294MAIN Board
- C294PSB Board
- C294PSE Board

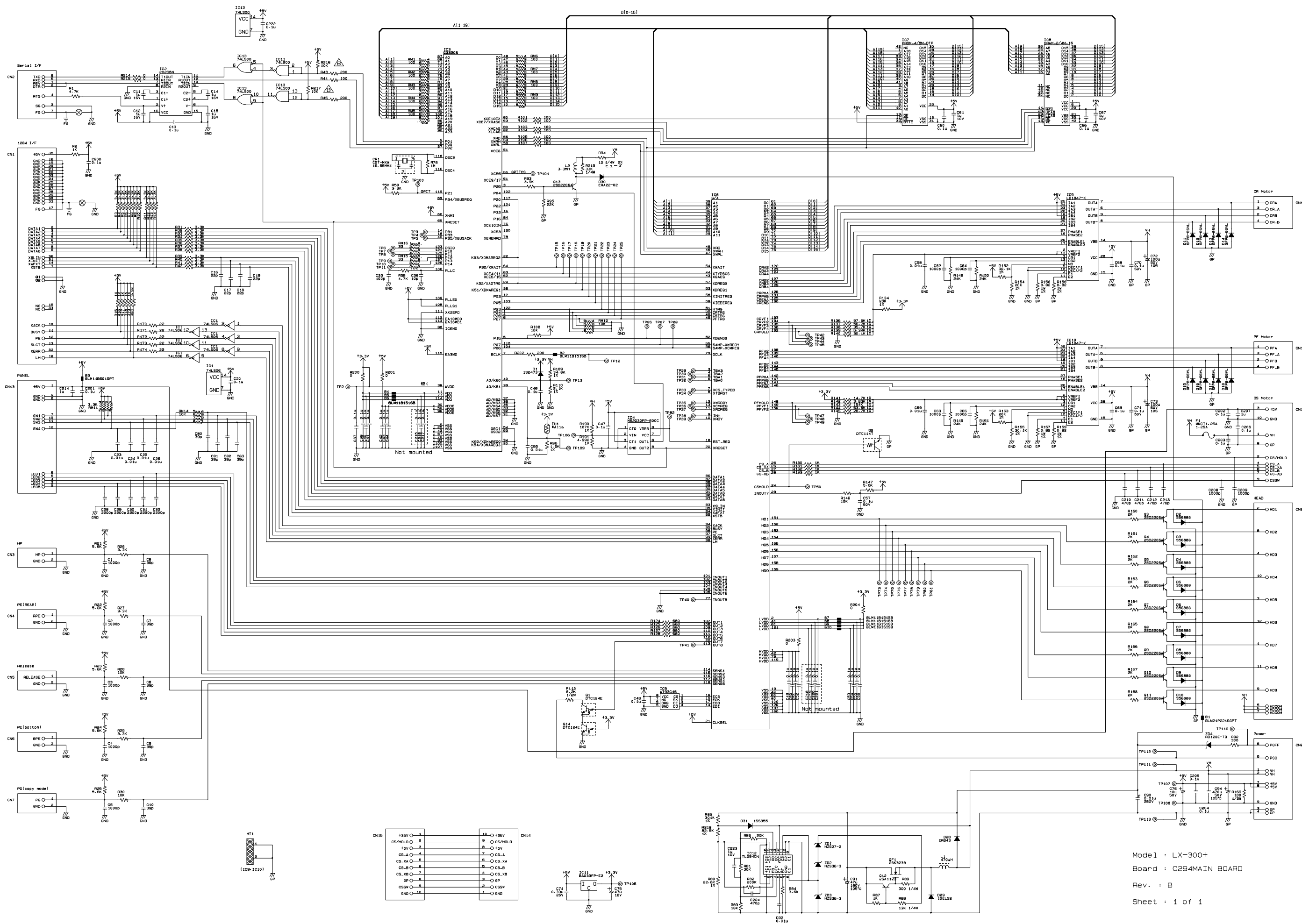

Model : LX-300+
 Board : C294MAIN BOARD
 Rev. : B
 Sheet : 1 of 1

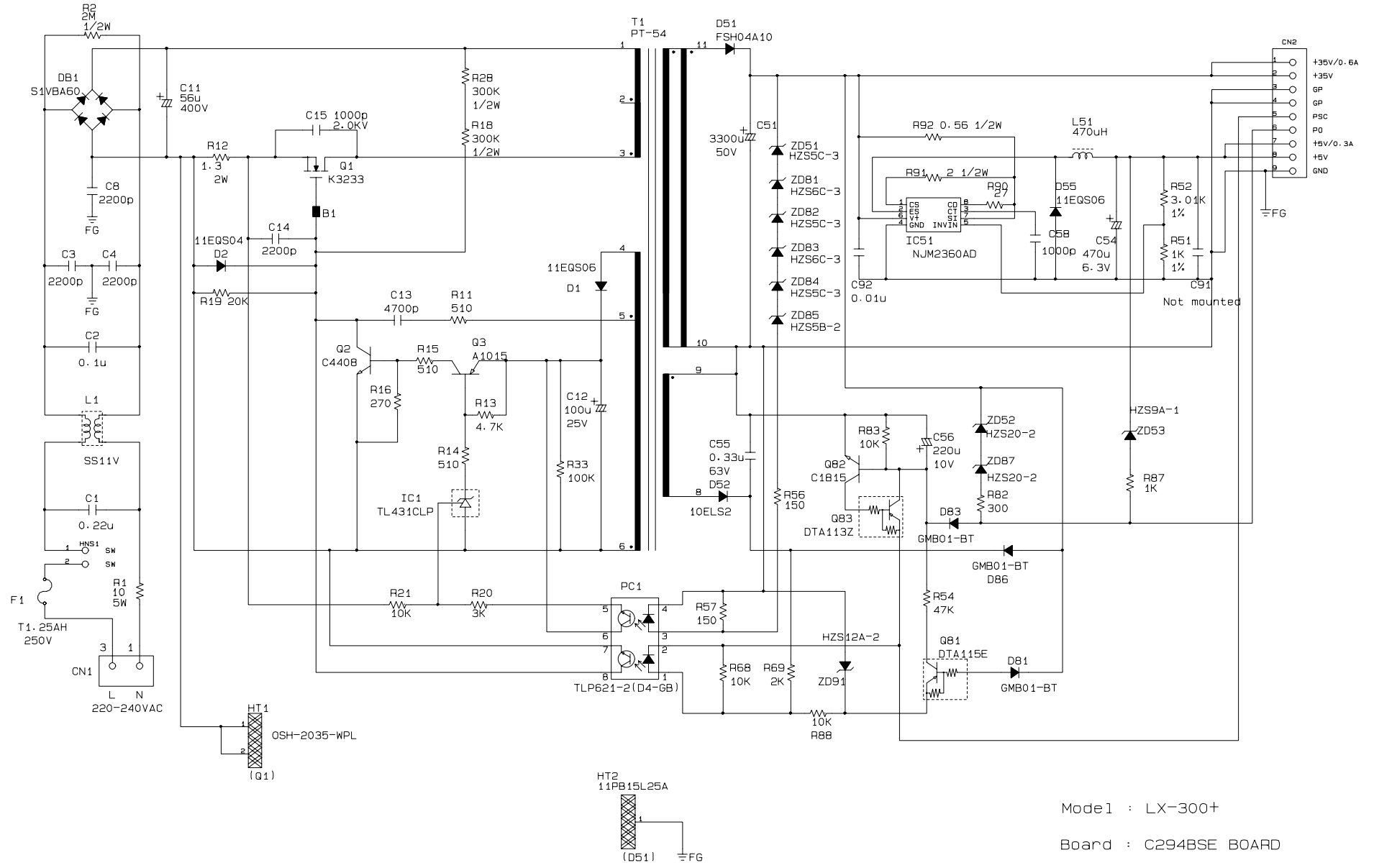

Mode1 : LX-300+
 Board : C294BSE BOARD
 Rev. : A
 Sheet : 1 of 1